

Montageanleitung

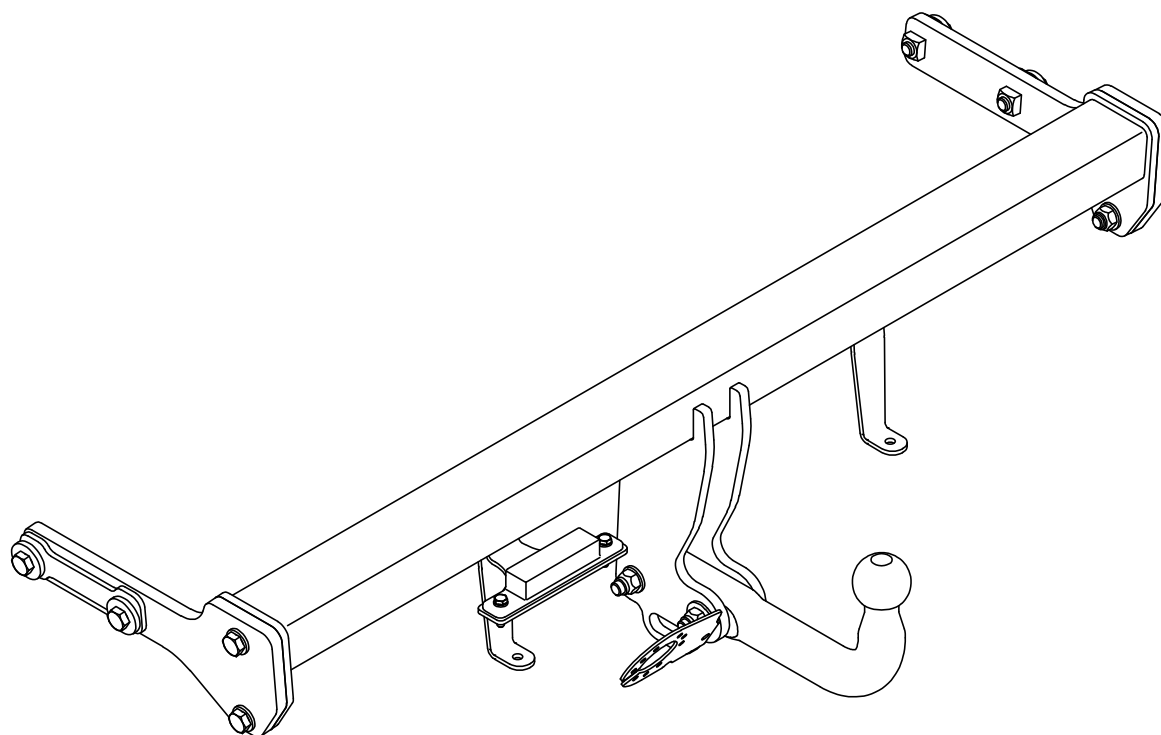

Fahrzeug-Modell: Hyundai Tucson	Fahrzeug-Typ: NX4e
Teilebezeichnung: Anhängekupplung 3148 B	Teilenummer: 9999Z-040576
Montagezeit: ca. 90 Minuten	
Ersatzteile:	
Technische Hotline:	+49 (0) 2403 7902-60 (Fon) +49 (0) 2403 7902-99 (Fax)

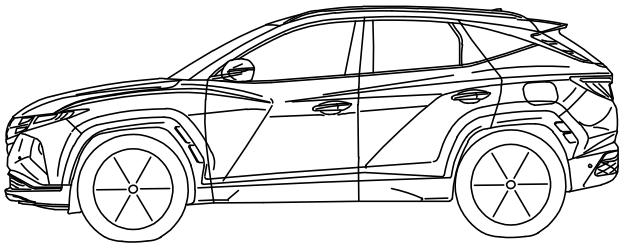



↓ ≤ 2245 kg



EG

e5 *2018/858*00001

$$D = 10,4 \text{ kN}$$



≤ 100 kg

kg ?

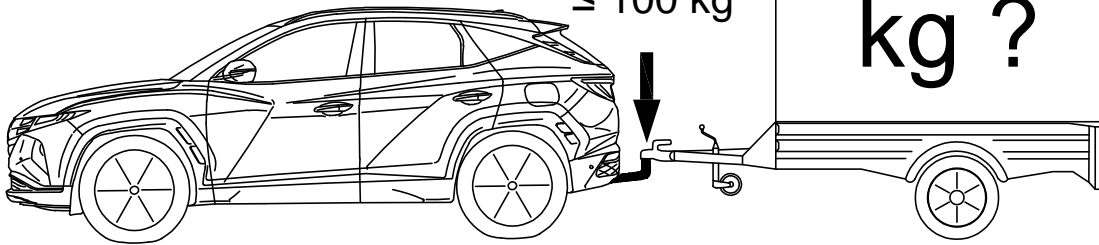

$$D = \frac{T \times R}{1000 \times (T + R)} \times g$$

$$g = 9,81 \text{ m/s}^2$$

$$T = \frac{R \times D \times 1000}{(g \times R) - (1000 \times D)}$$

T - kg

R - kg

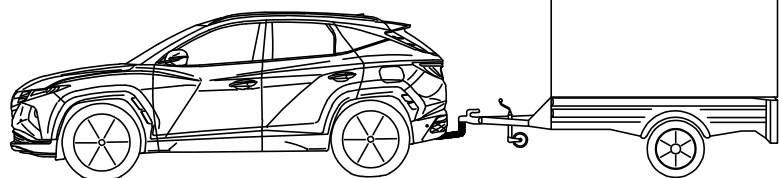

$$R = \frac{T \times D \times 1000}{(g \times T) - (1000 \times D)}$$

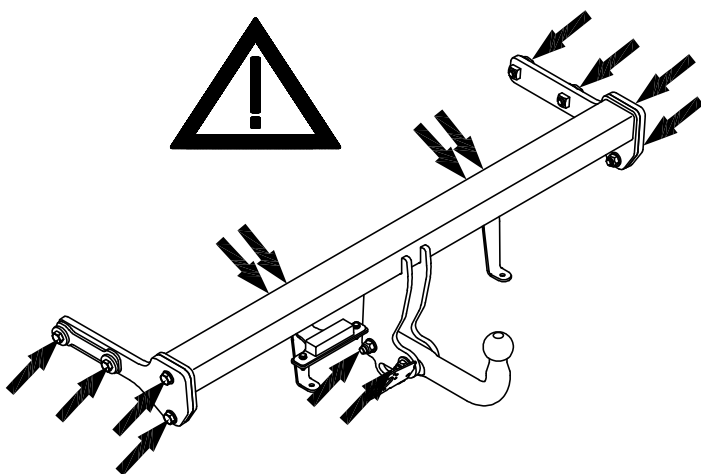
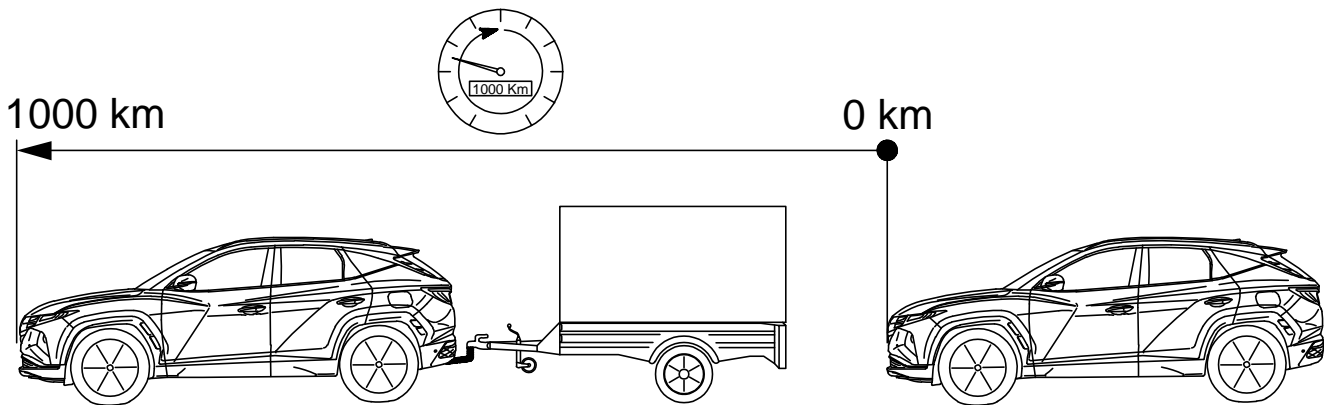
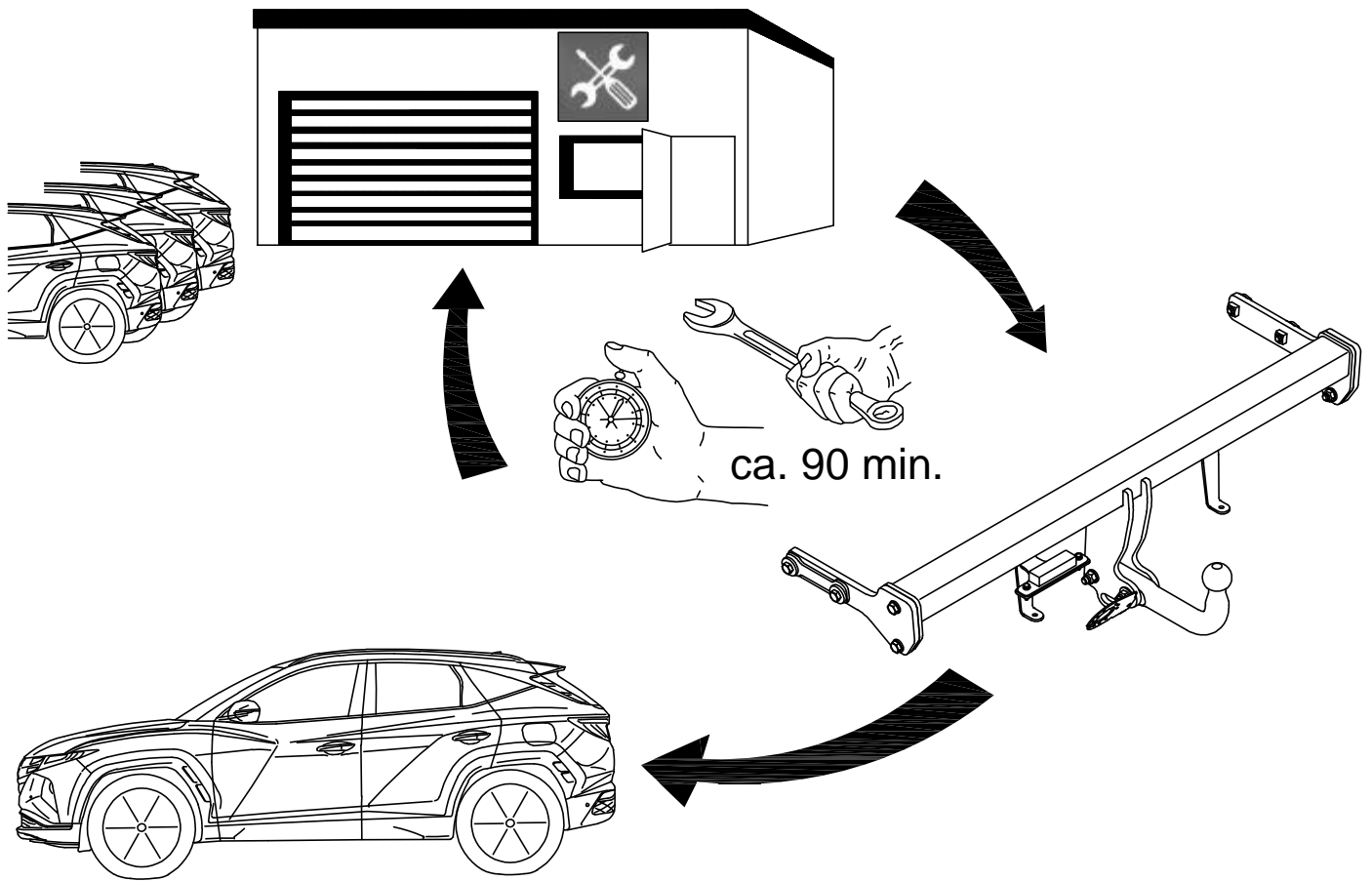

	M6	8 Nm 100 Nm
	M12	

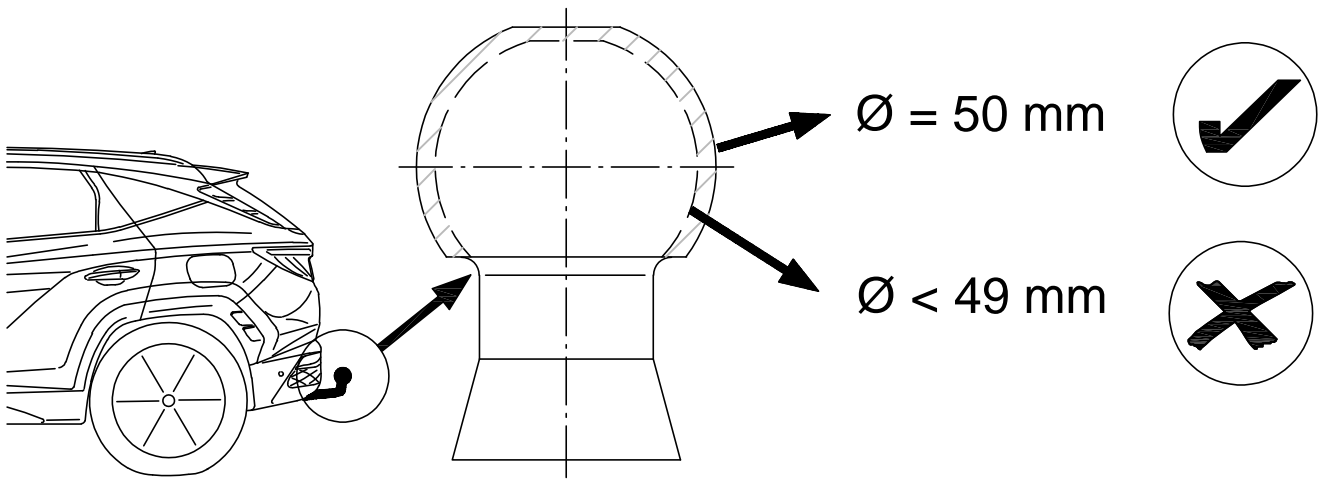

MVG[®] Approval Number
 MVG-Metalverarbeitungsgesellschaft mbH **(E4) 55R-01 1033**
 Type: 3148 B D-Value: 10,4 kN
 Class: A50-X S-Value: 100 kg
 Made in Germany www.mvg-ahk.de

Zulässige Stützlast maximal 100 kg
MVG[®]
 MVG-Metalverarbeitungsgesellschaft mbH
www.mvg-ahk.de

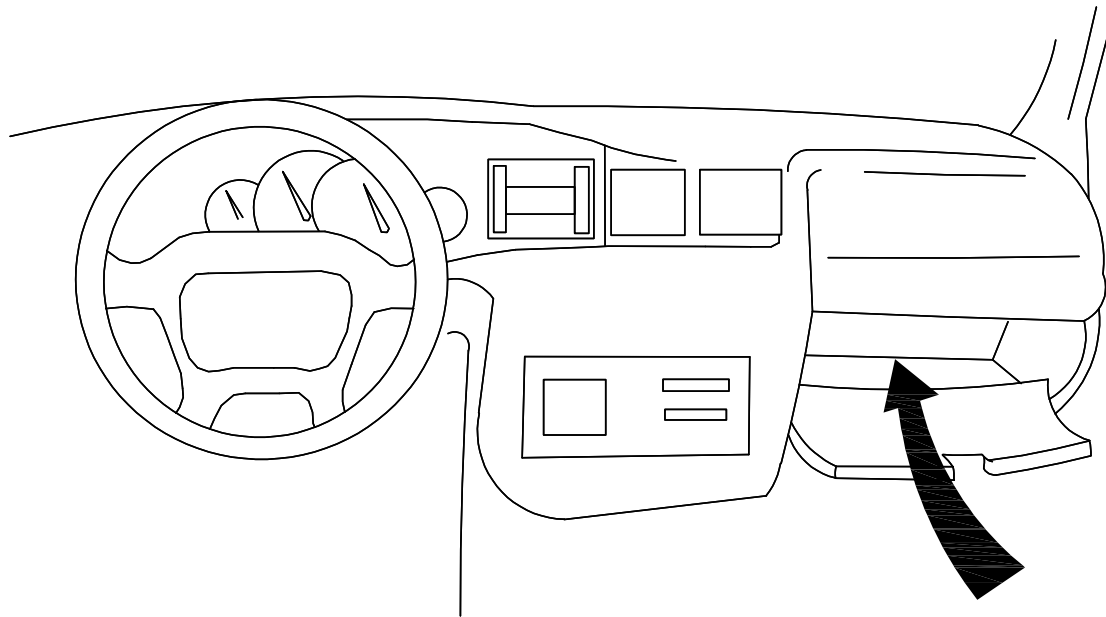







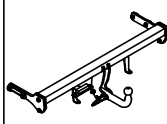





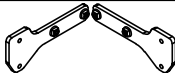



Technische Änderungen vorbehalten

Montageanleitung 

Produkttyp	Produkttyp
Produktname	Produktname
Produktbeschreibung	Produktbeschreibung
Montageanleitung	Montageanleitung
Technische Daten	Technische Daten
Herstellernummer	Herstellernummer
Produktionsjahr	Produktionsjahr



 <p>siehe Werkstatthandbuch</p>	 <p>Nicht Entsorgen</p>	 <p>Entsorgen</p>	 <p>Von Hand</p>
 <p>Achtung</p>	 <p>Bewegungspfeil</p>	 <p>Positionspfeil</p>	 <p>Stecker lösen/ verbinden</p>
 <p>Nur zu zweit ausführen</p>	 <p>Ohne Druckluft</p>	 <p>Nicht ölen</p>	 <p>Seitenschneider verwenden</p>
 <p>Festdrehen</p>	 <p>Siehe Abbildung</p>	 <p>Reinigen</p>	 <p>Von Hand festdrehen</p>
 <p>Unterbodenschutz entfernen</p>	 <p>Gegen Korrosion schützen</p>	 <p>Bohrer verwenden</p>	 <p>Kleben</p>
 <p>Anzeichnen</p>	 <p>Schneiden</p>	 <p>Feilen/ Entgraten</p>	 <p>Licht kontrollieren</p>

1	1x		3148 B		
2	1x		2000 B 54.0		
3	2x				
4	je1		(links & rechts)		
5	8x		M12x40 (10.9)	ISO 4017	
6	4x		Ø13/ 35x5	DIN 6340	
7	9x		Ø13/ 24x2,5	ISO 7089	
8	4x		M12 (10)	ISO 7042	
9	2x				
10	1x				
11	6x		M6x25 (8.8)	ISO 4017	
12	12x		Ø6,4/ 12x1,6	ISO 7089	
13	6x		M6 (8)	ISO 7042	
14	1x				
15	2x		M12x80 (10.9)	ISO 4017	
16	1x		3148 B		
17	1x			0062	
18	1x		100 kg	1016	

E Volumen de suministro del enganche

D Lieferumfang der Anhängervorrichtung

GB Scope of delivery of towing hitch

F Pièces comprises dans la fourniture de l'attelage

NL Leveringsomvang trekhaak

S Dragkrokens leveransspecifikation

CZ Objem dodání tažného zařízení

I Dotazione del gancio di traino

Manufactured for Hyundai



An der Wasserwiese 1
D-52249 Eschweiler

E-mail: info@mvg-ahk.de
Internet: www.mvg-ahk.de

Fon: +49 (0) 2403 7902-60
Fax: +49 (0) 2403 7902-99

Modellnummer	1800000000
Produktname	Stützfuß
Produktcode	1800000000
Produktbeschreibung	Stützfuß für den MGV 1800000000
Produkttyp	Stützfuß
Produktgröße	1800000000
Produktgewicht	1800000000
Produktfarbe	1800000000

Zulässige Stützlast
maximal 100 kg



www.mvg.info

1

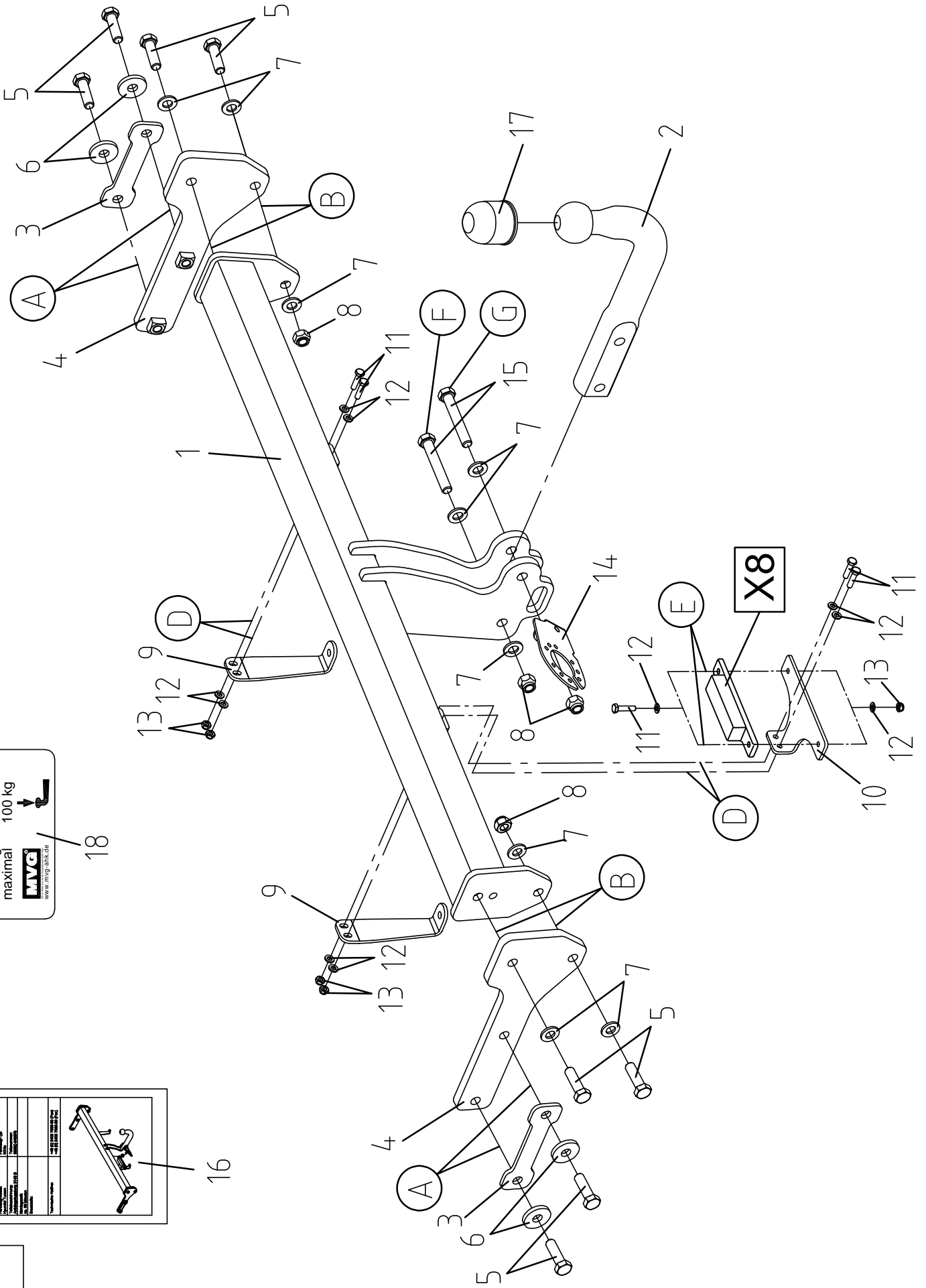

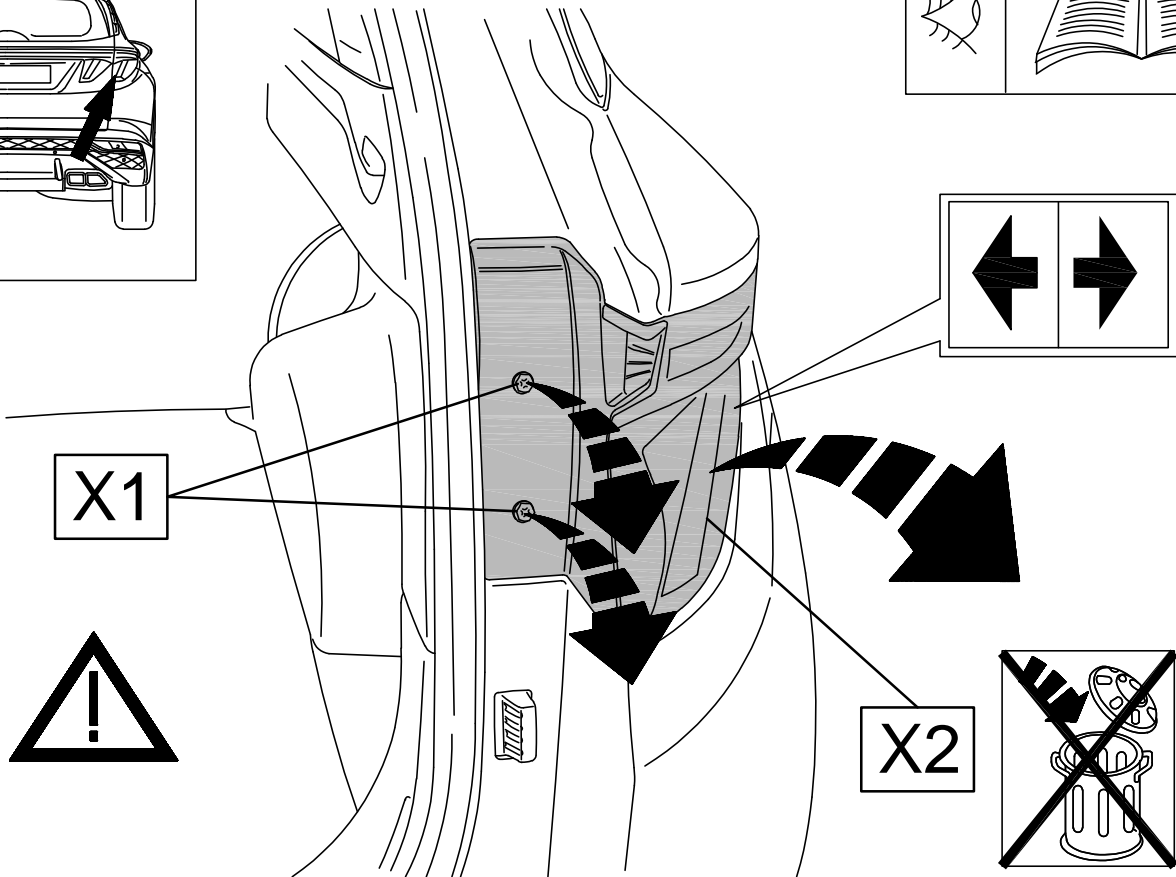
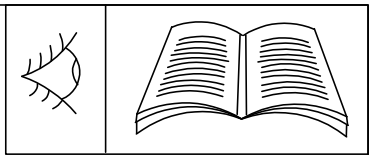
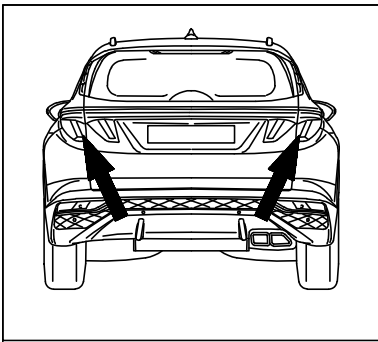

2

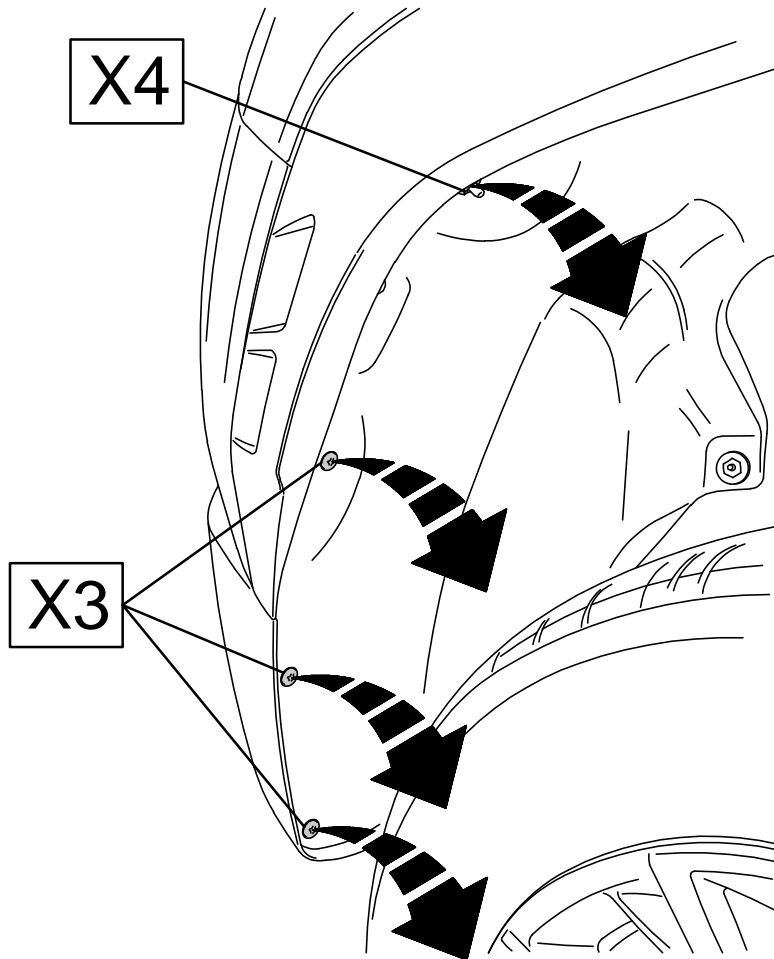
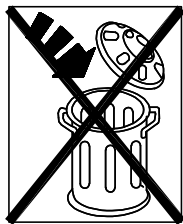
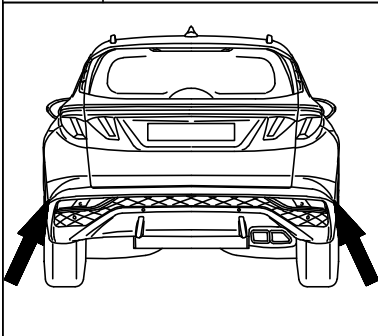

3

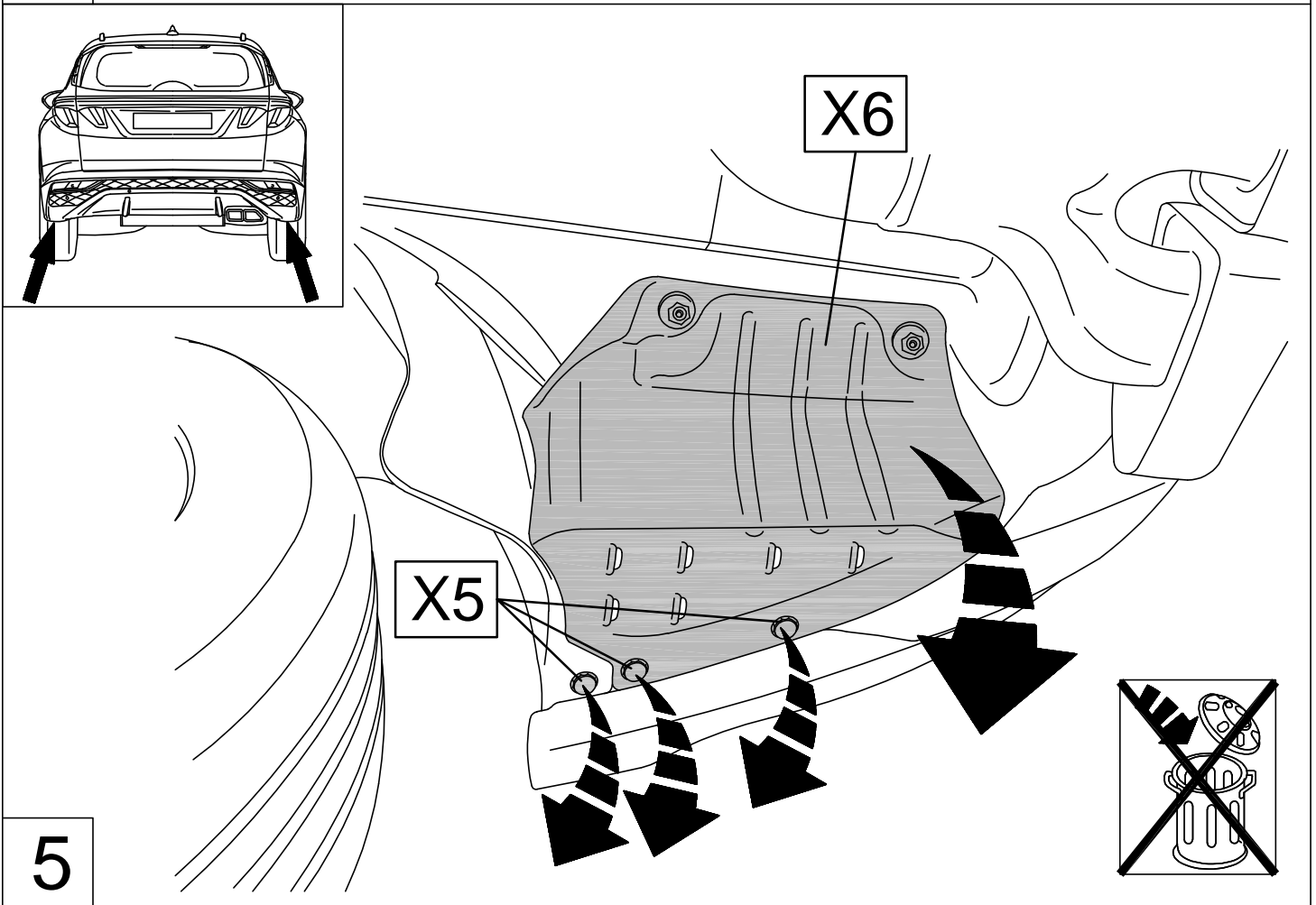
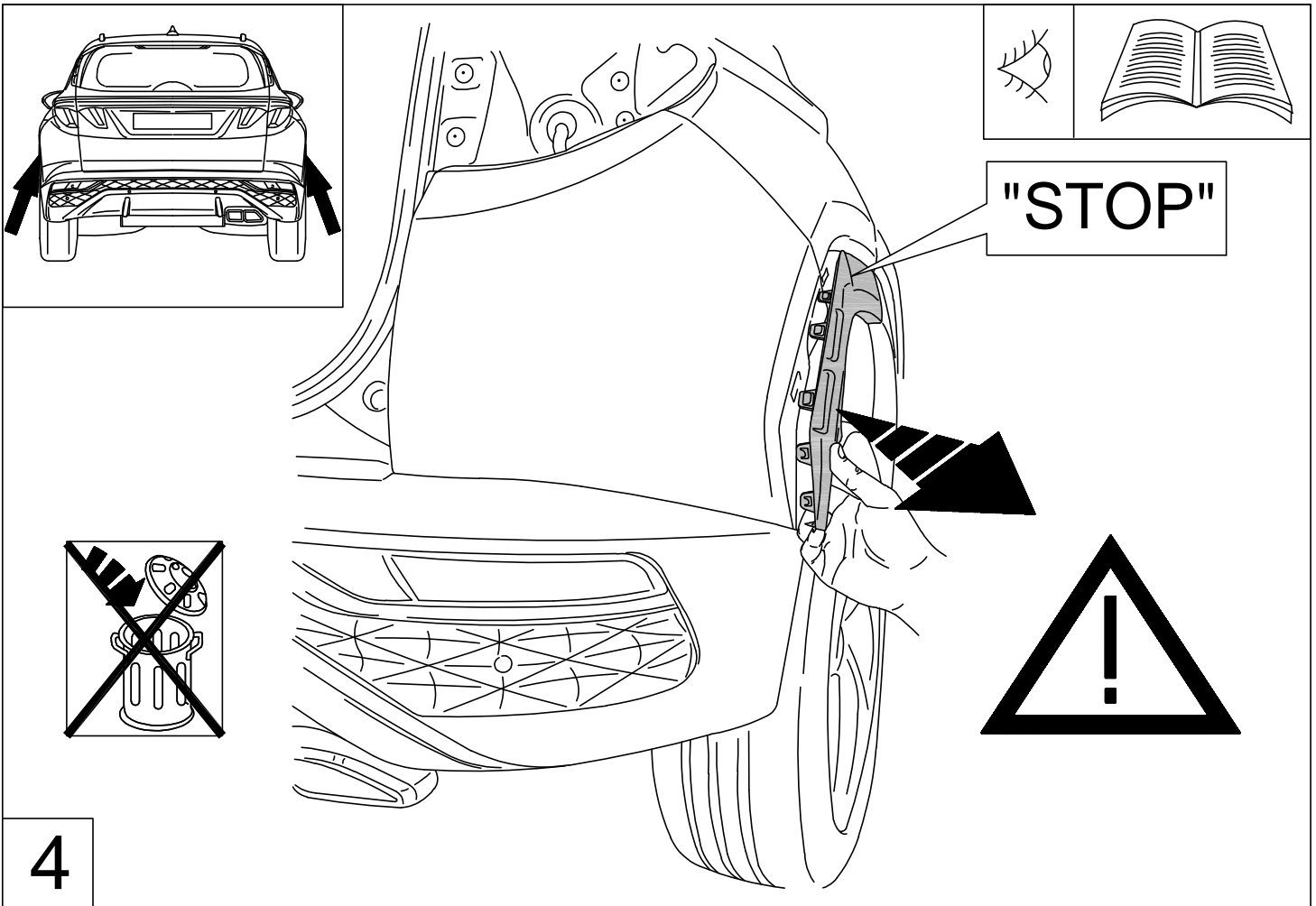



Diesel/ AdBlue

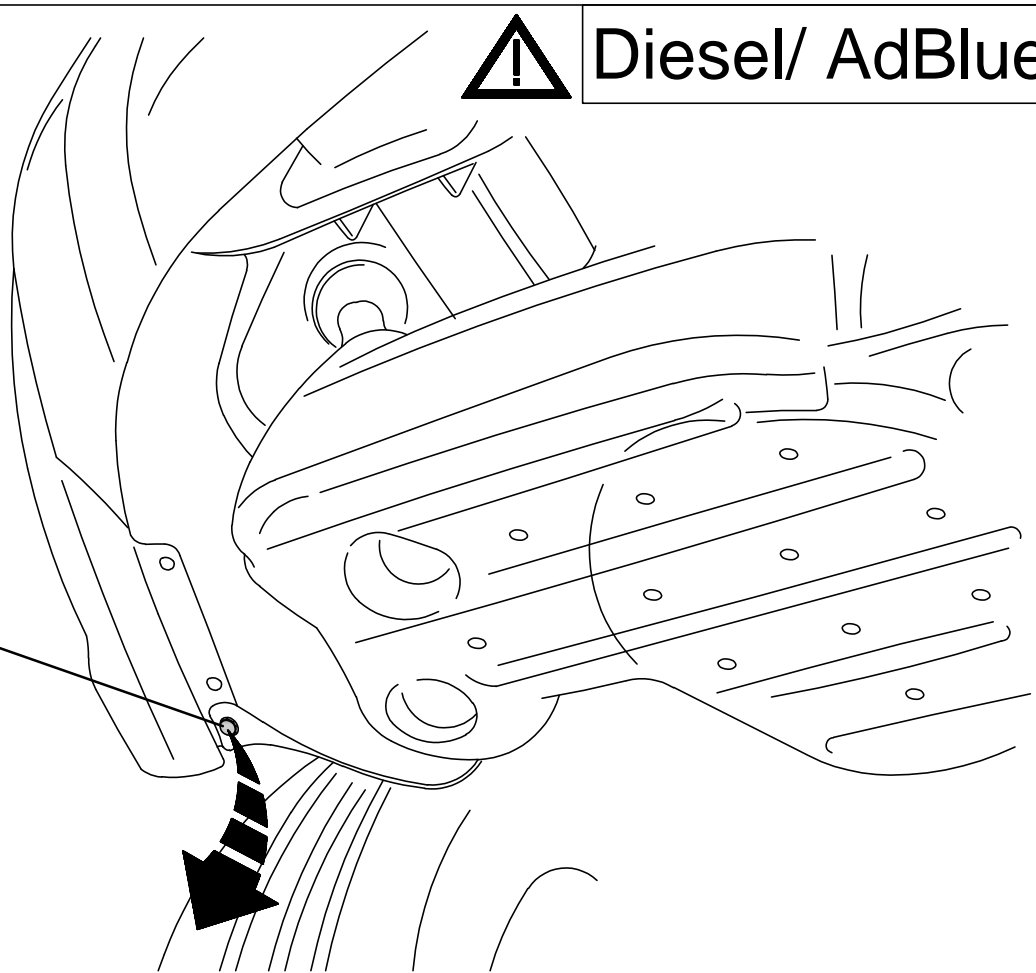
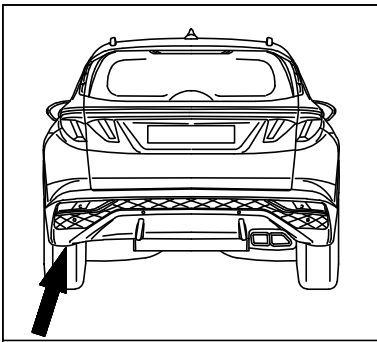

X5

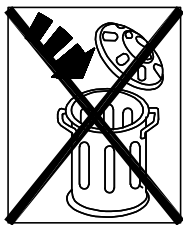

6

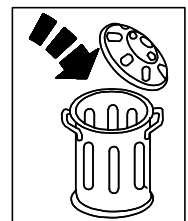
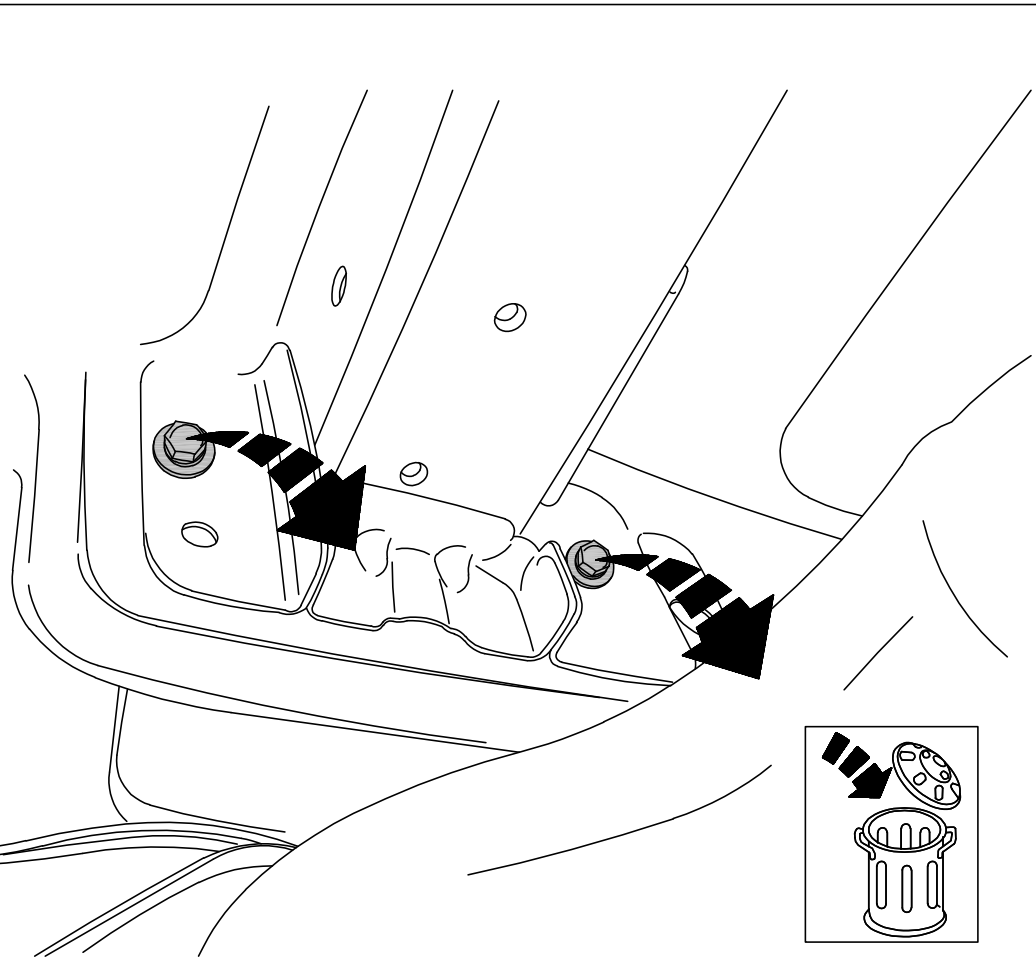
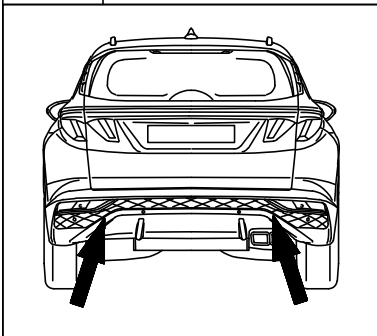

7

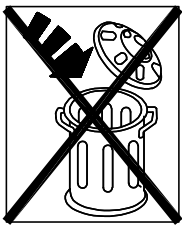
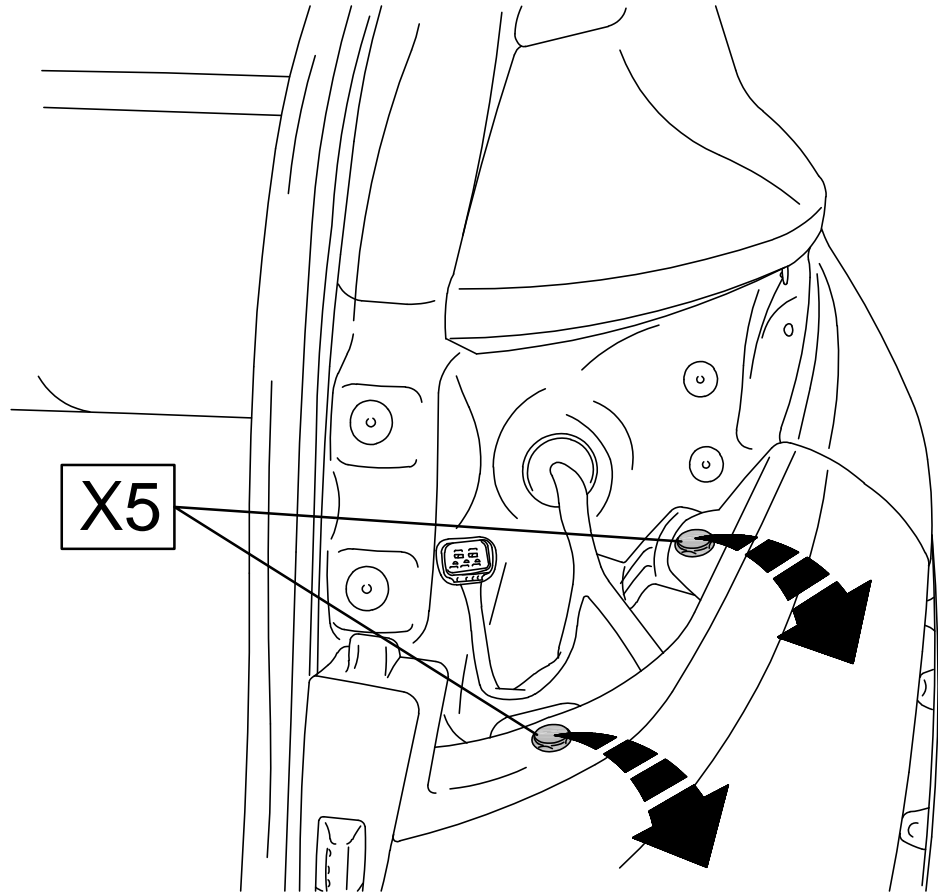
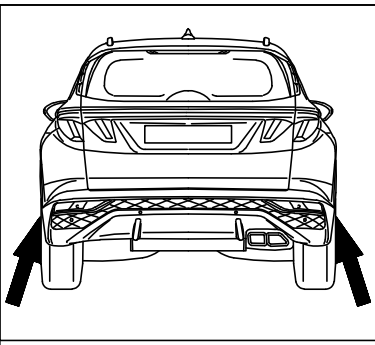

8

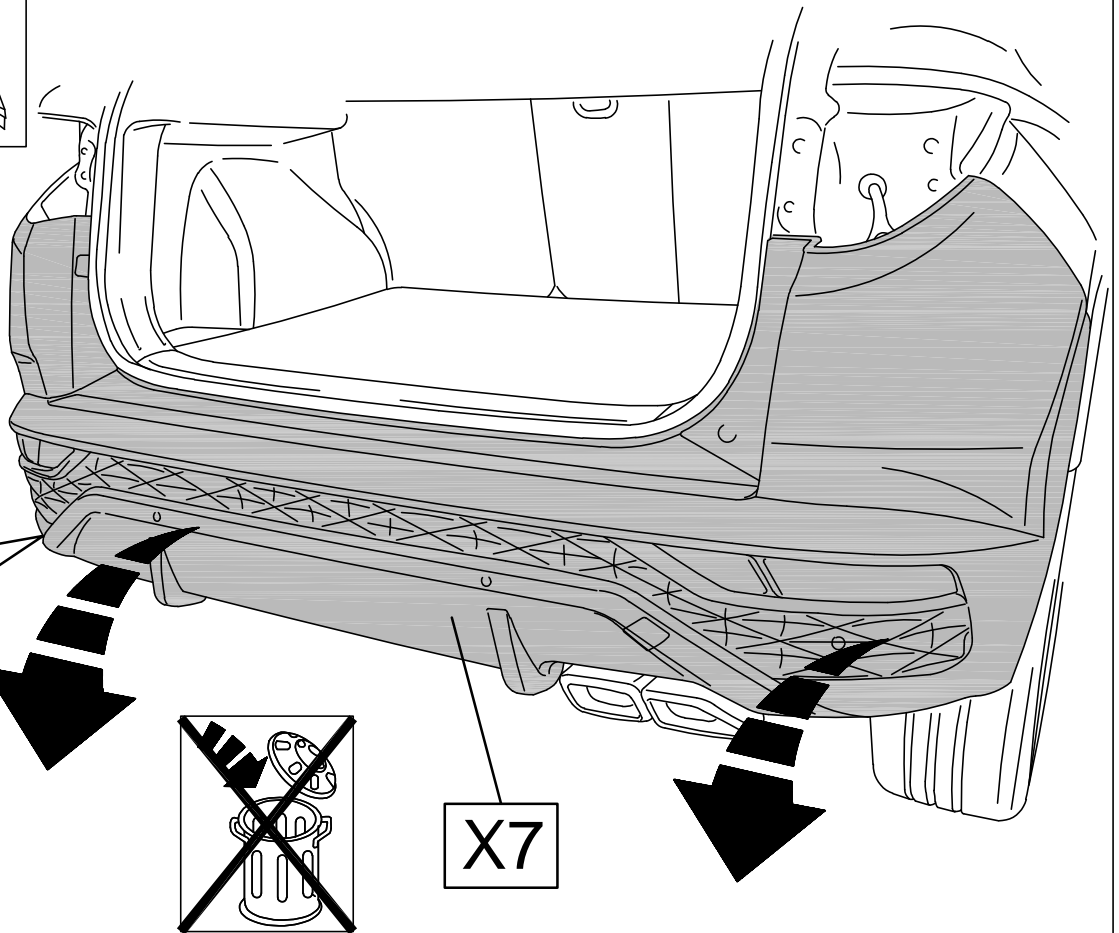
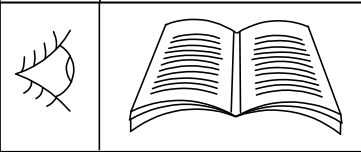

9

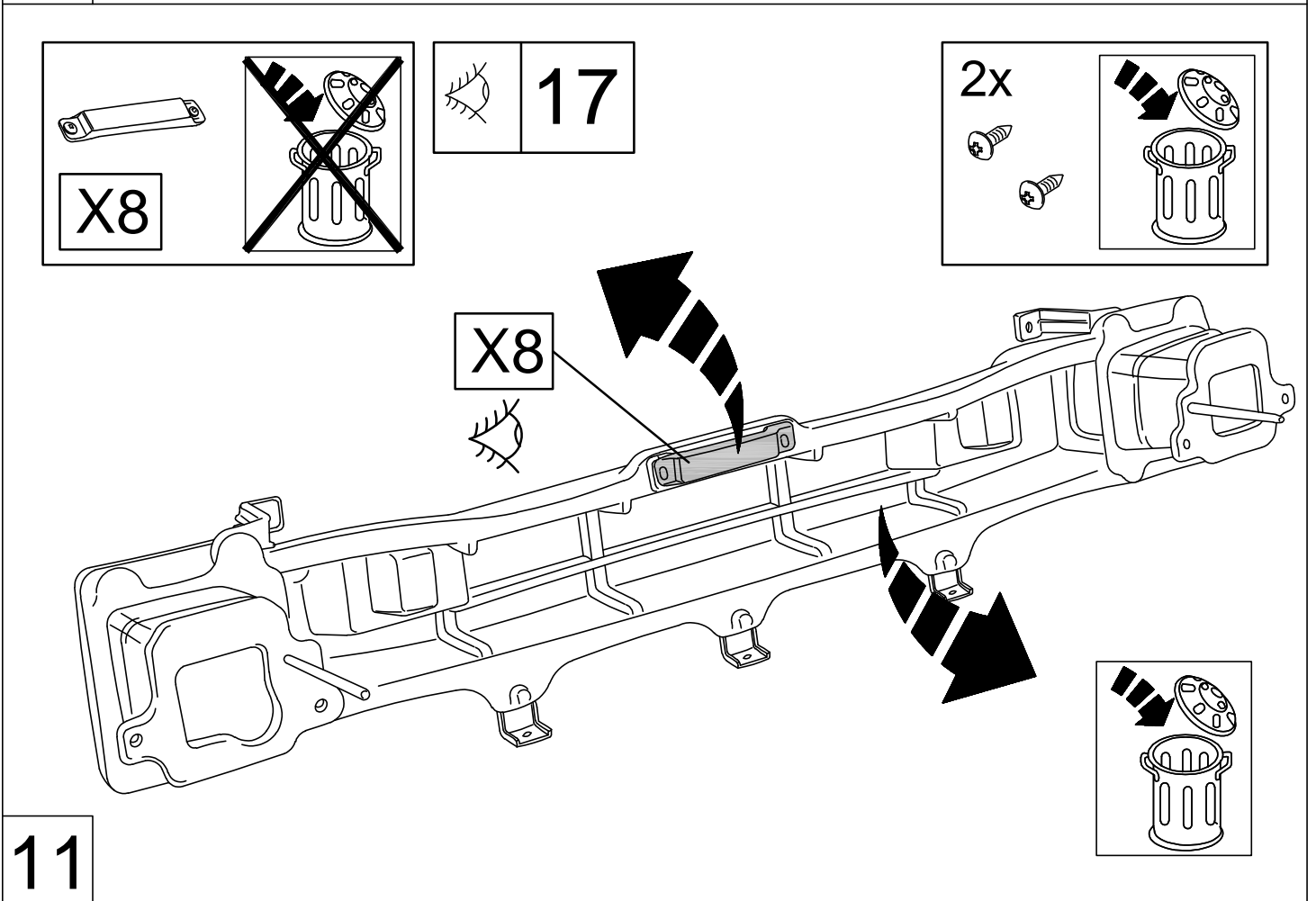
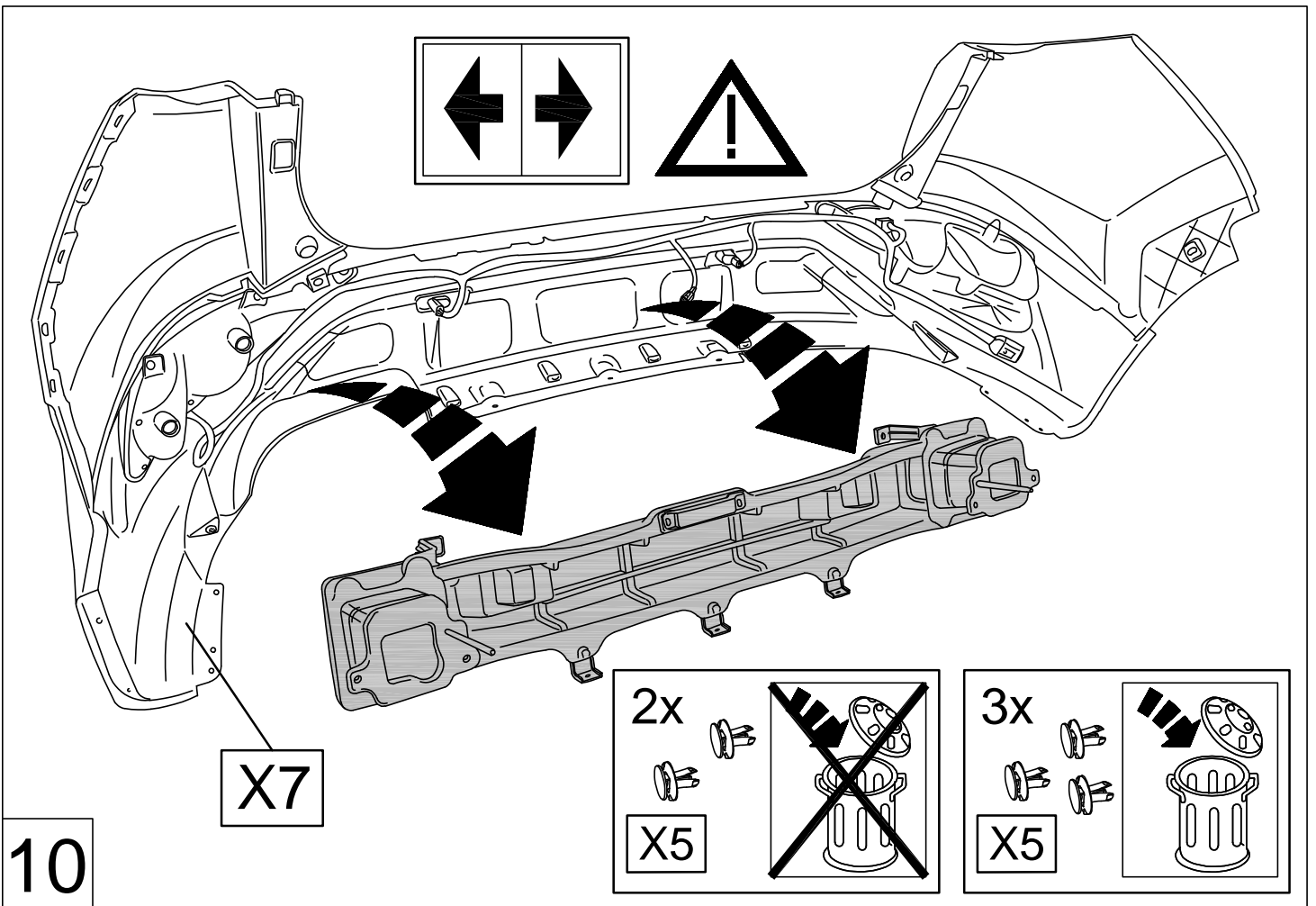

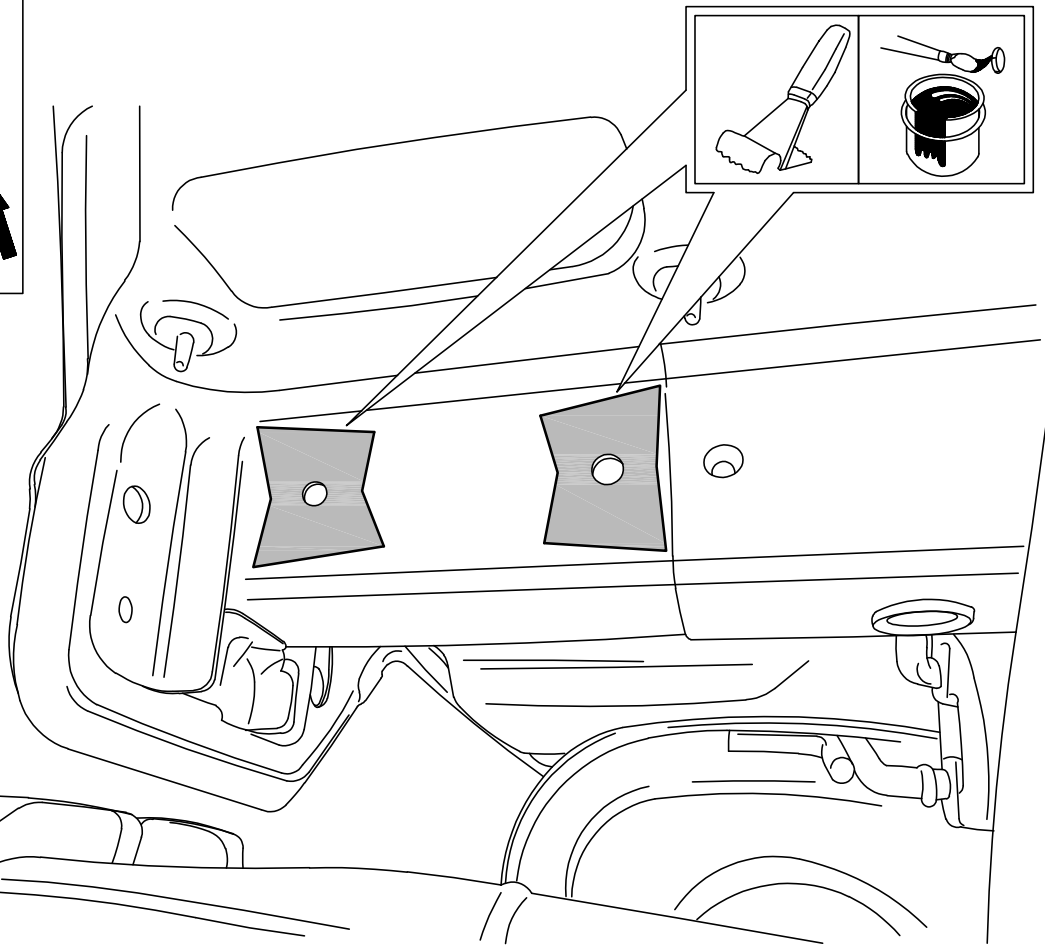
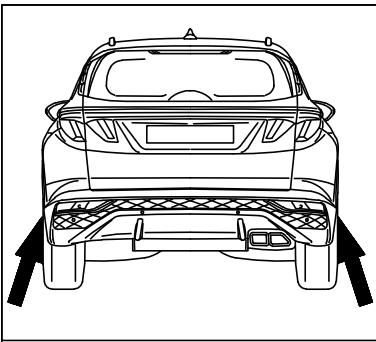

12

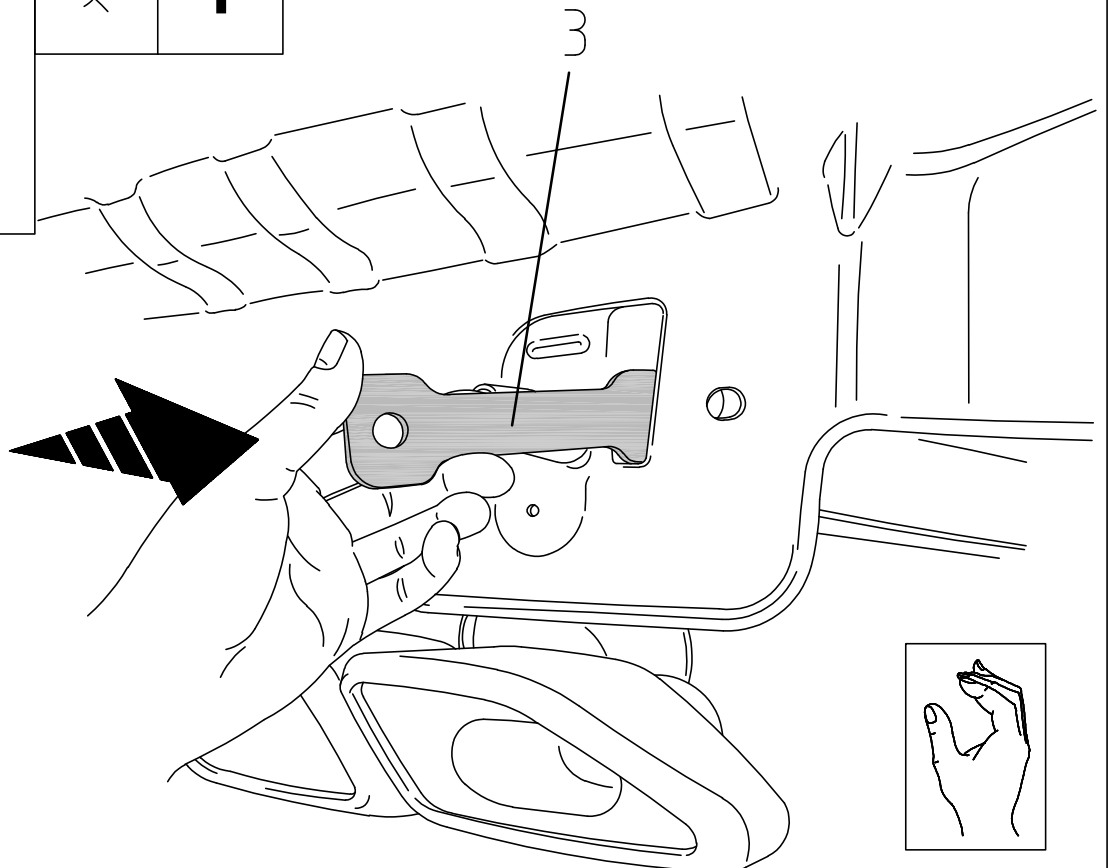
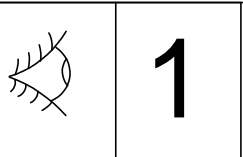
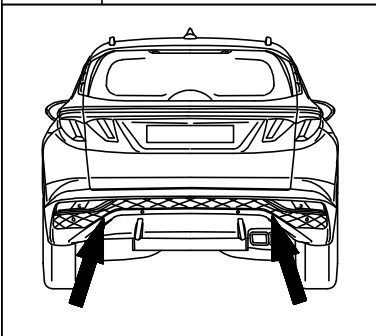

13

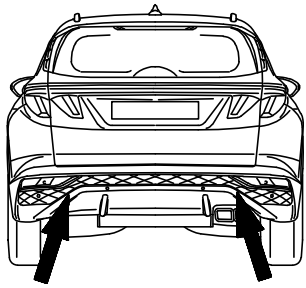

1

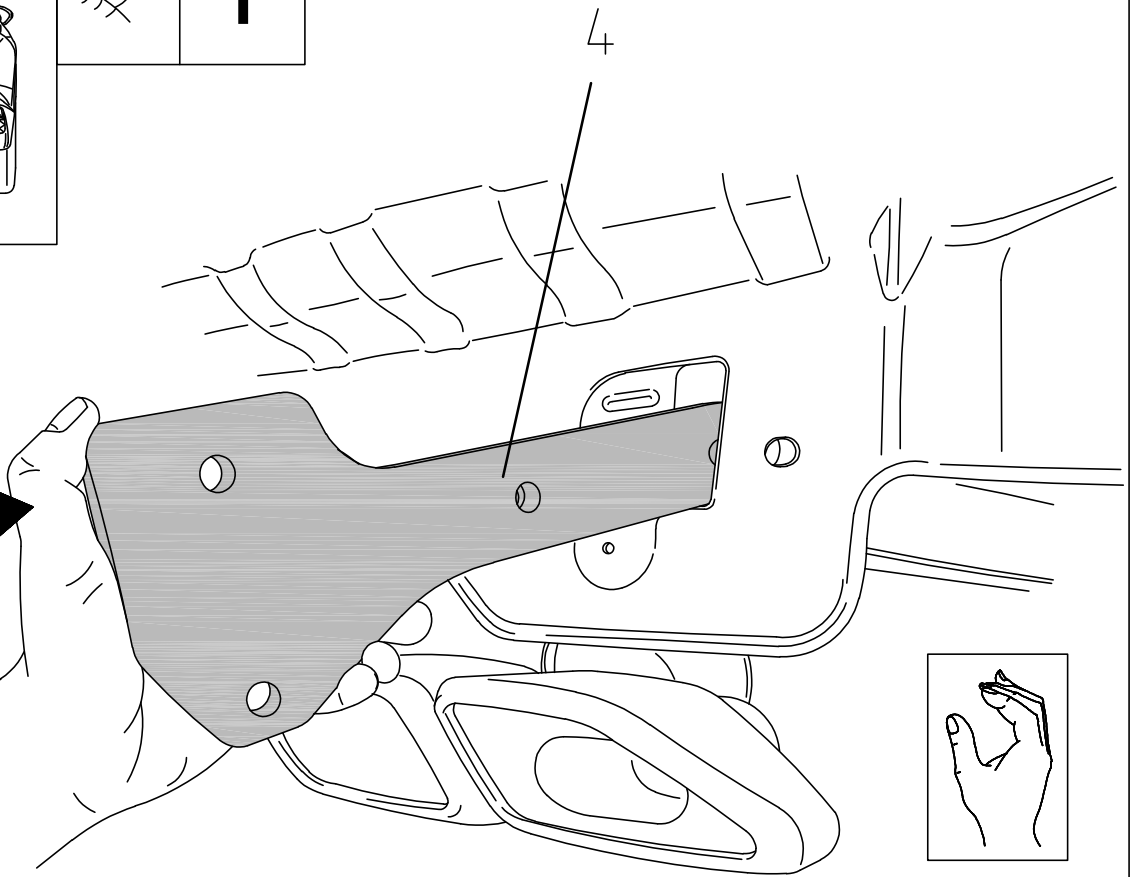
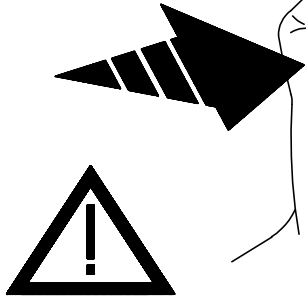

14

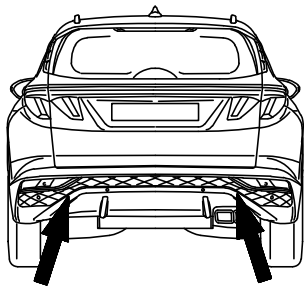

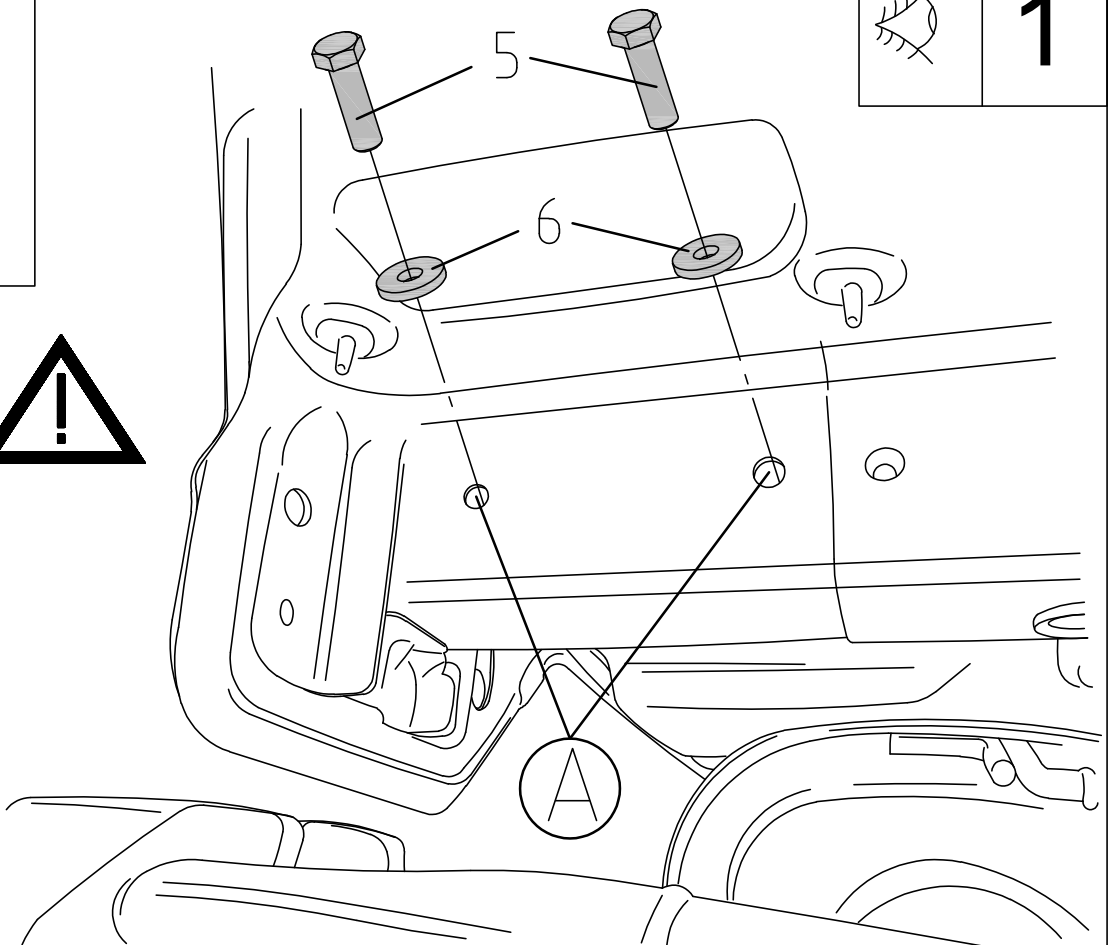
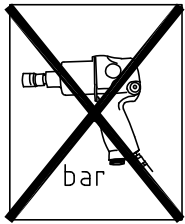
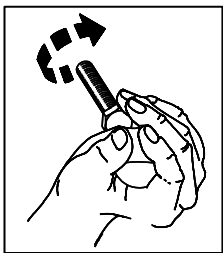

1

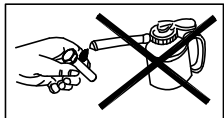

15

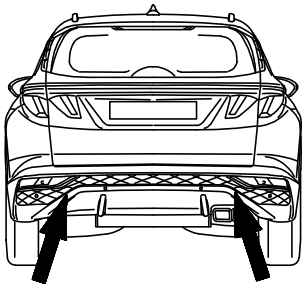



	M12	10.9	100Nm
--	-----	------	-------

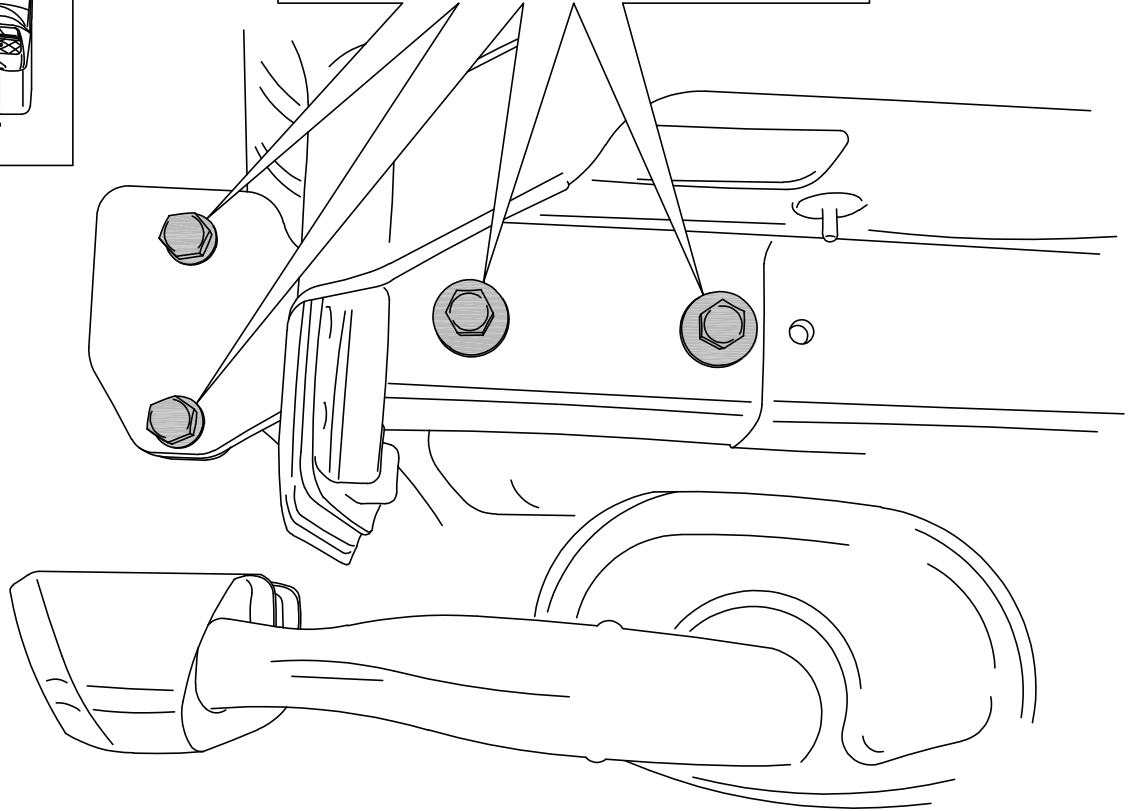
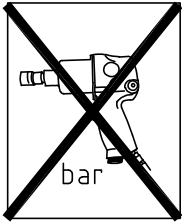

18

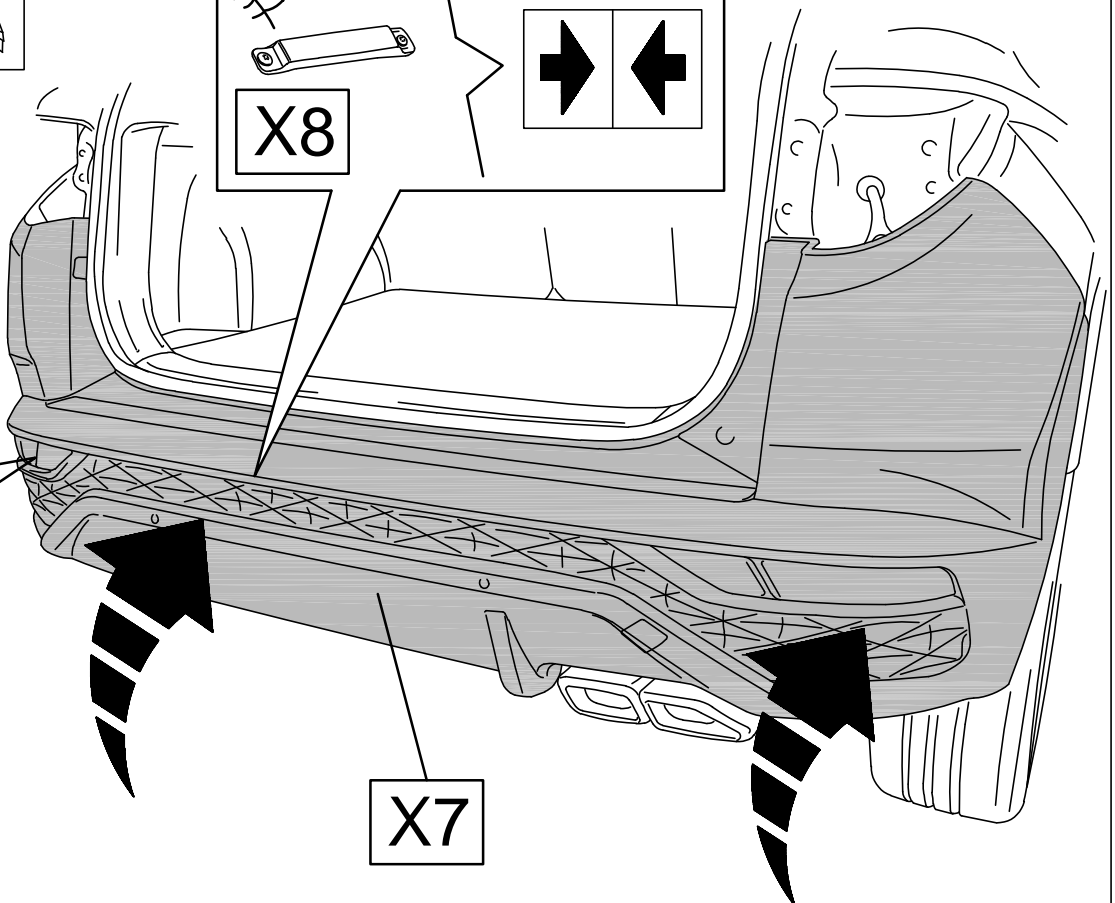
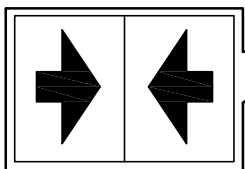
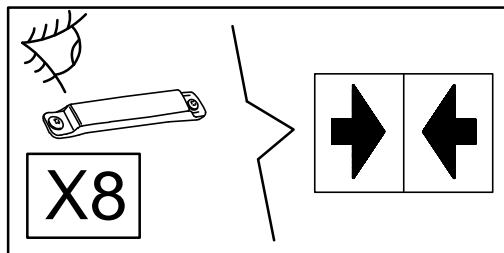

19

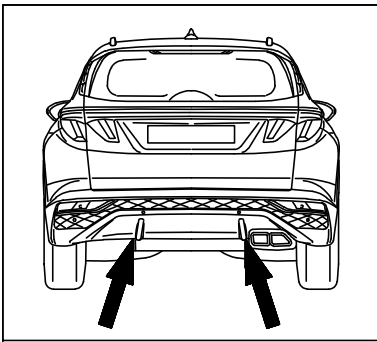

2.

	M6	8.8	8Nm
--	----	-----	-----

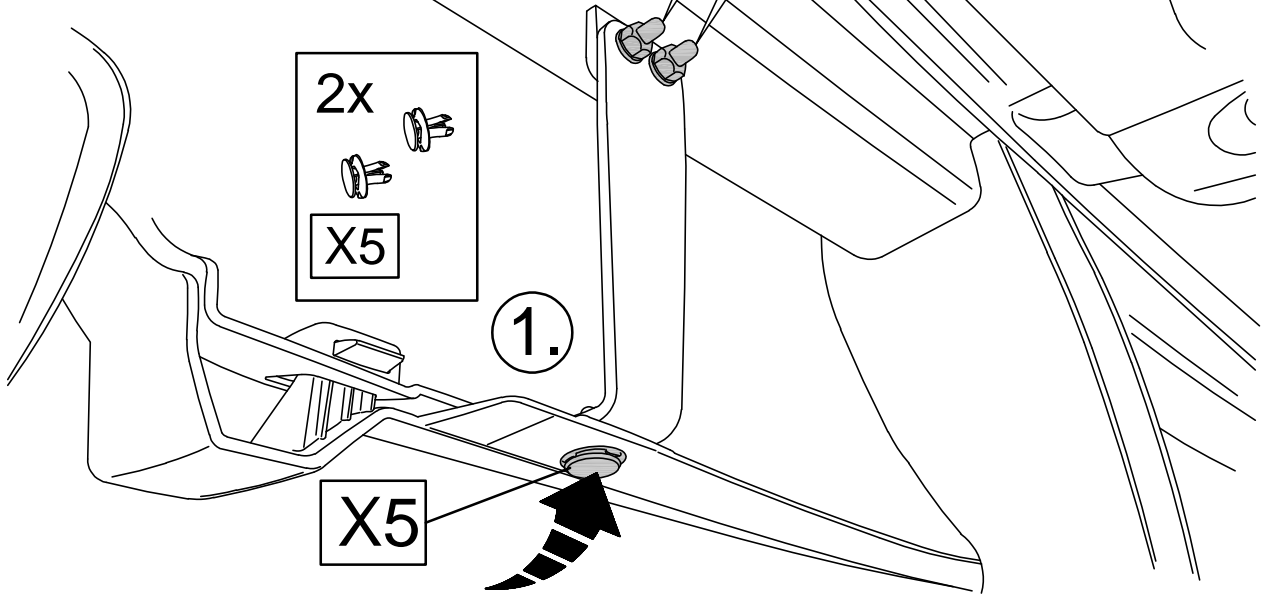

20

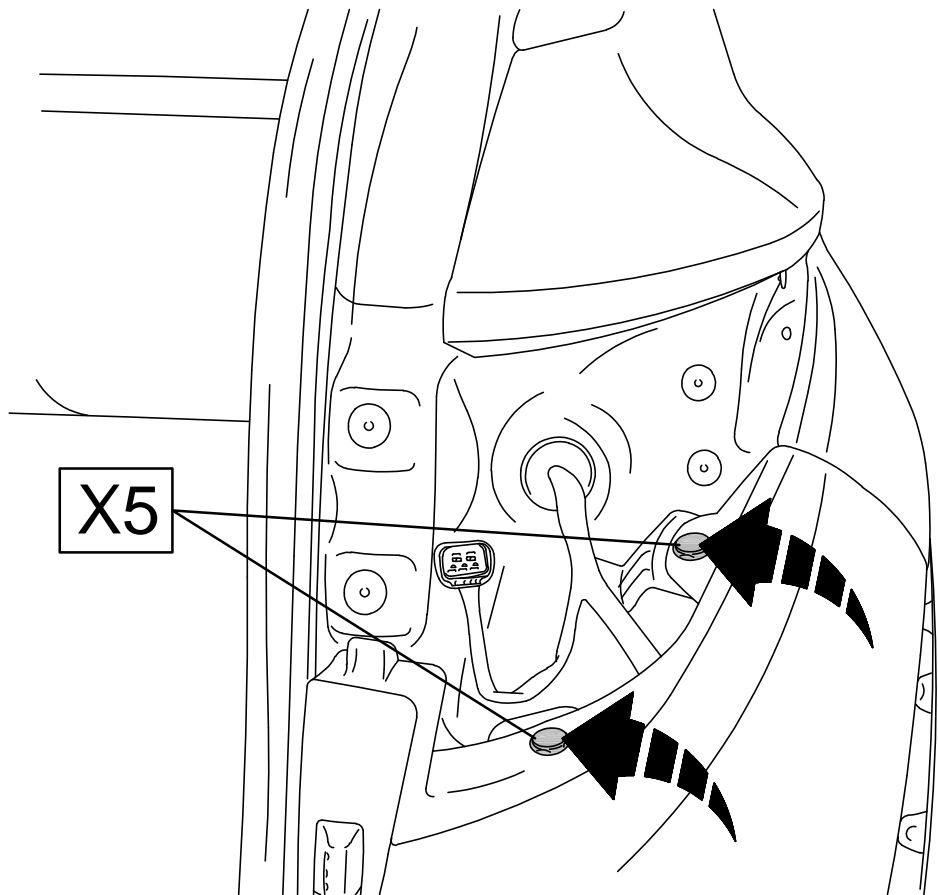
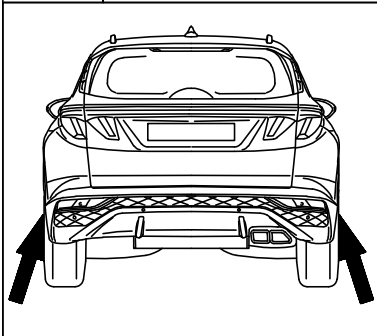

21

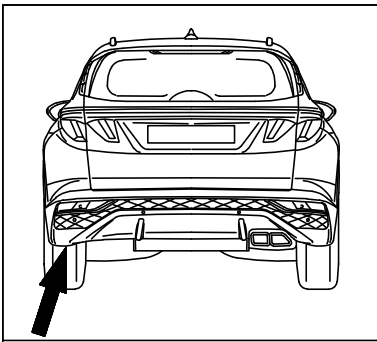

Diesel/ AdBlue

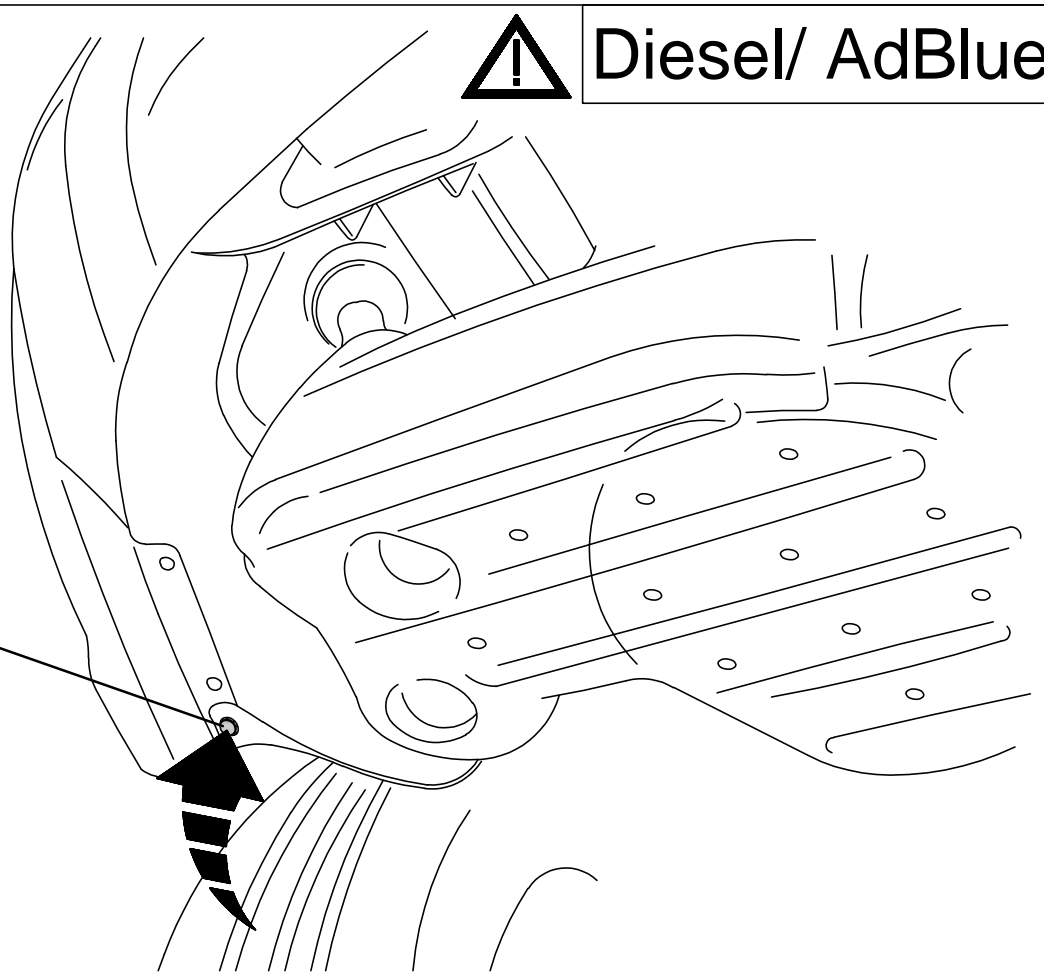

X5

22

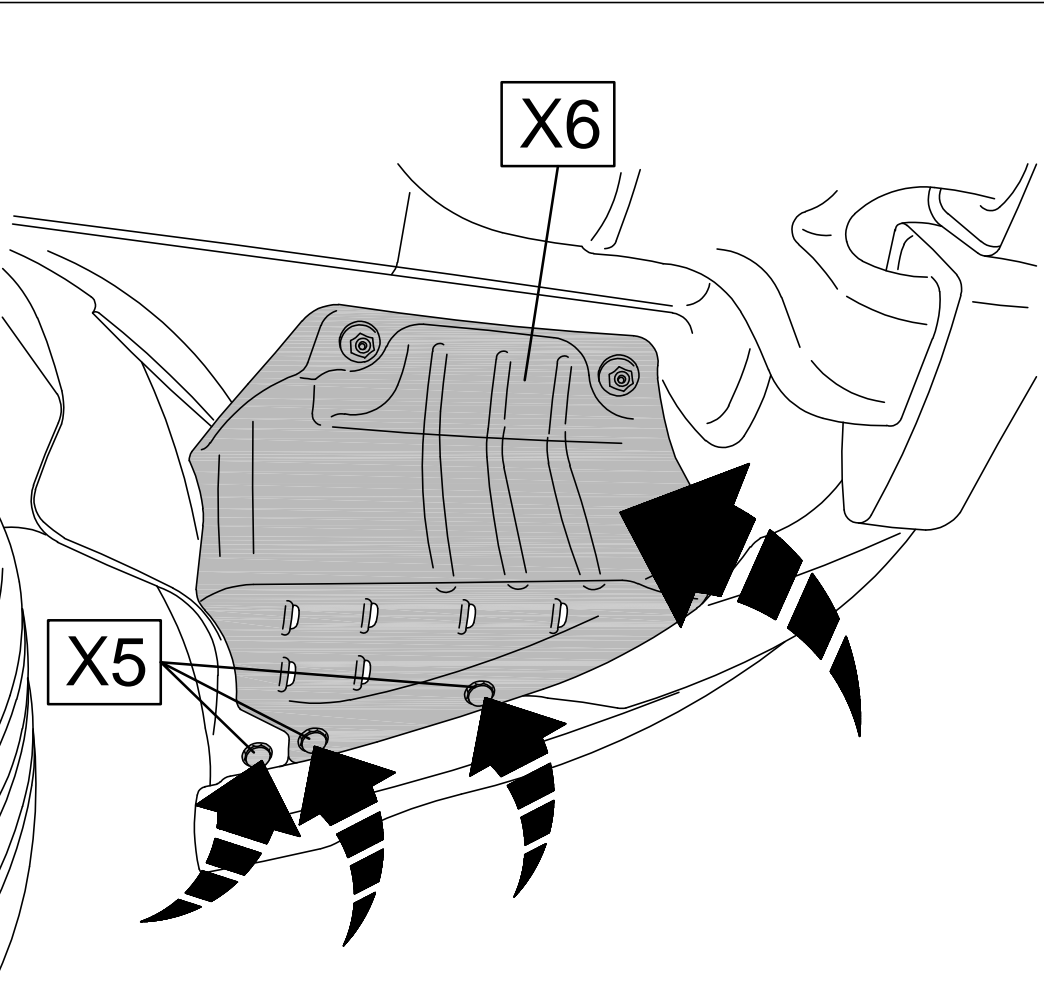
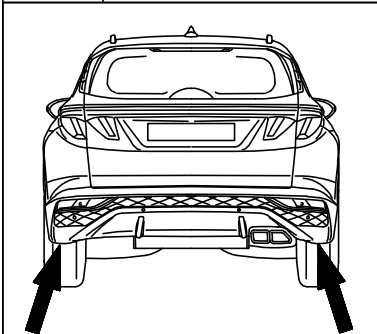

X6

X5

23

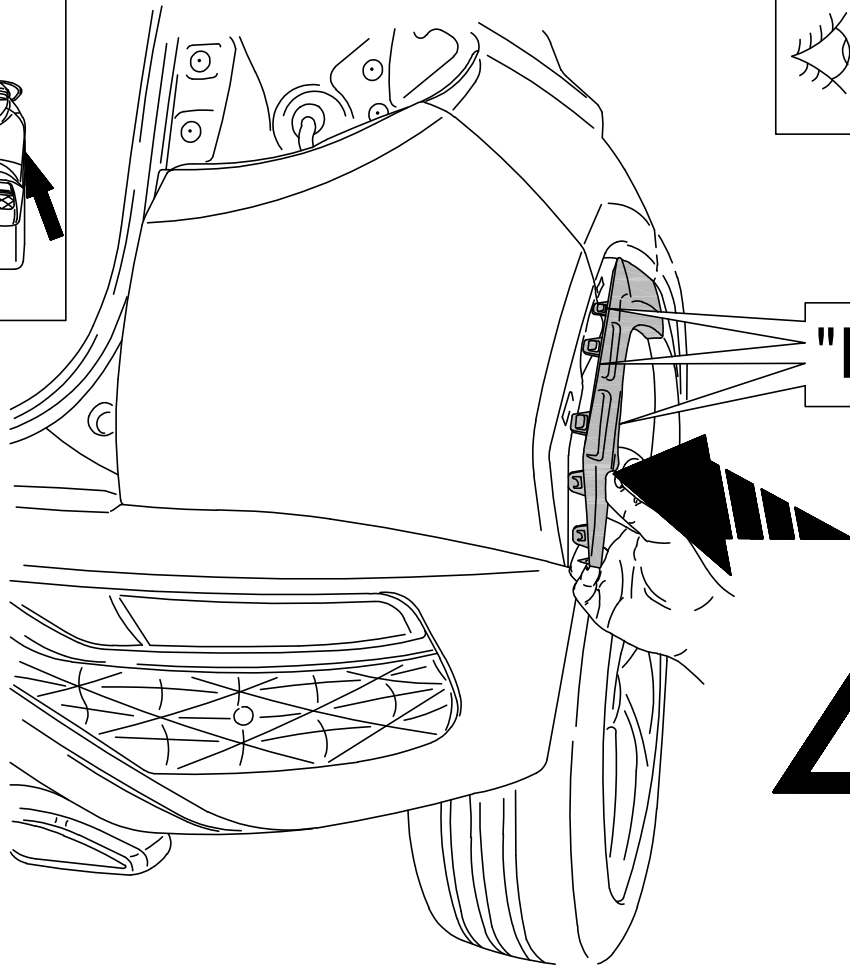
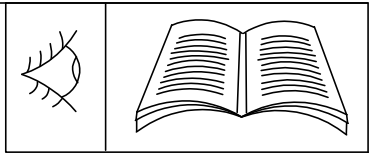
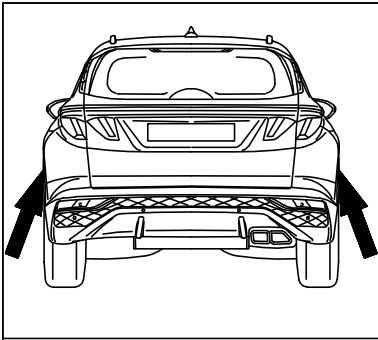

24

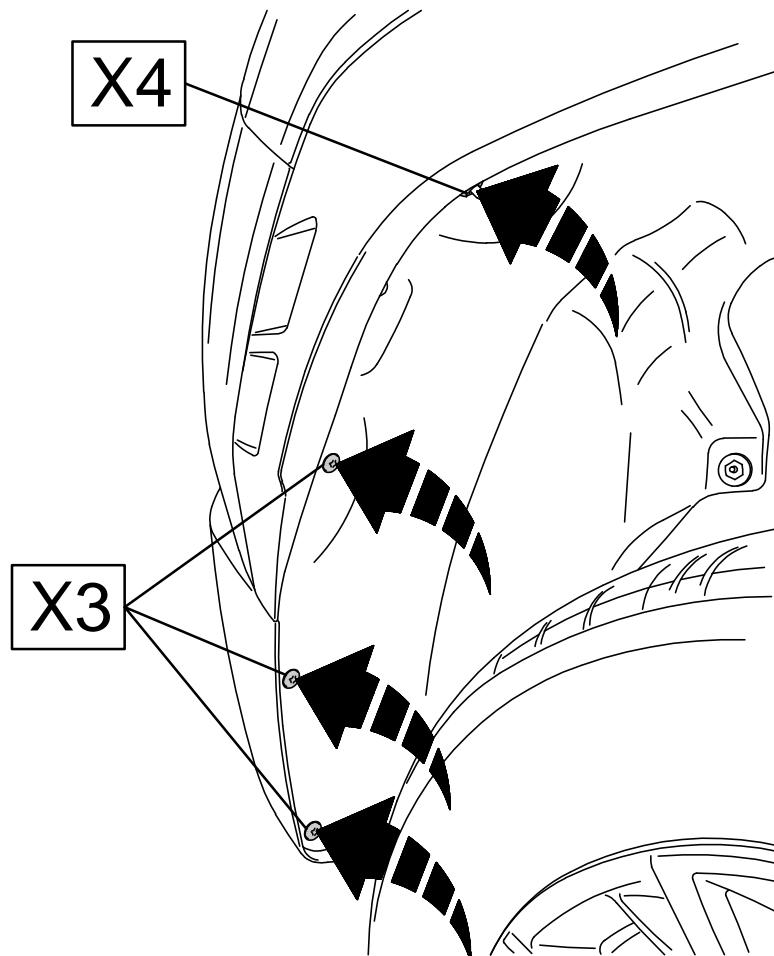
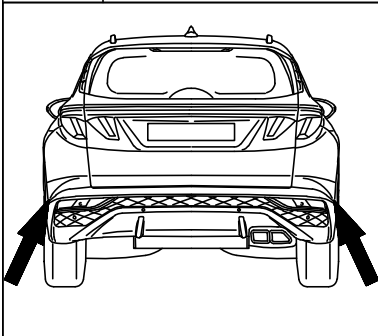

25

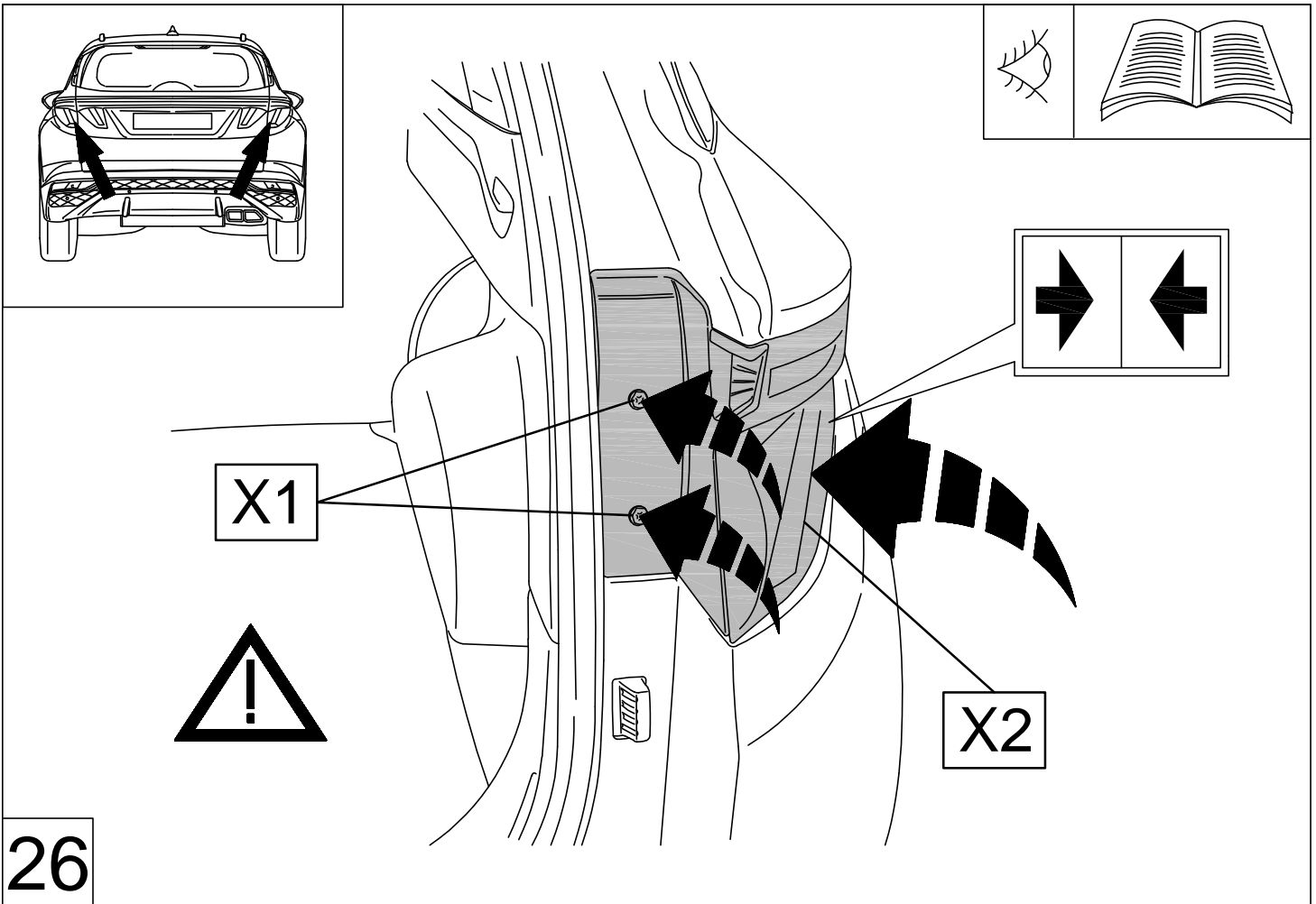

26

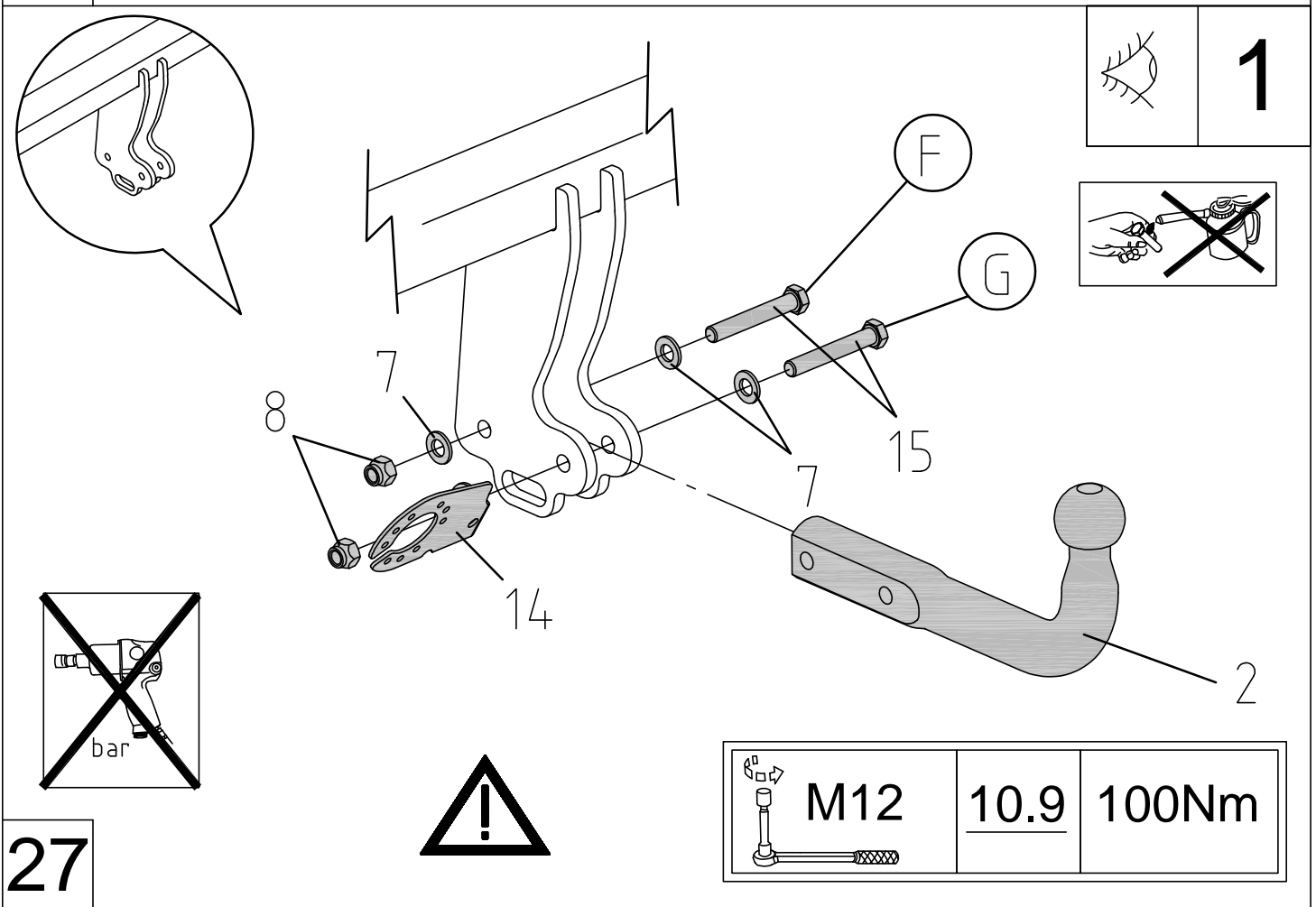

27

	M12	<u>10.9</u>	100Nm
--	-----	-------------	-------

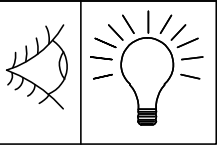

Zulässige Stützlast maximal 100 kg
MVG
www.mvg-ahk.de

24

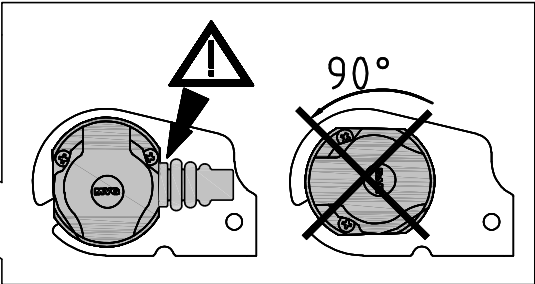
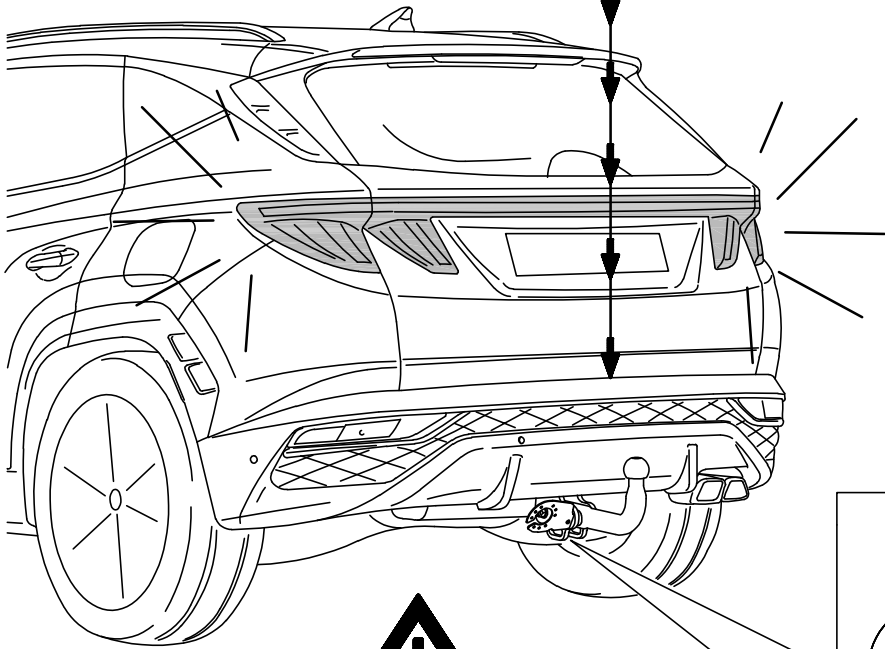

28

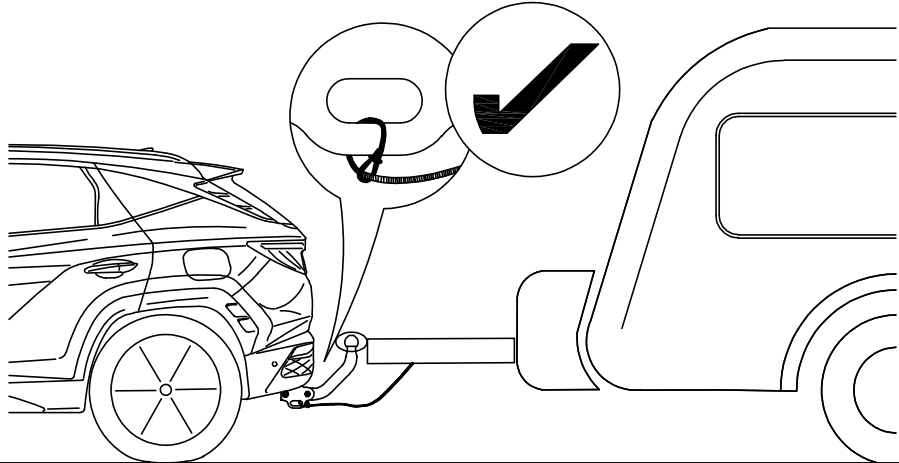
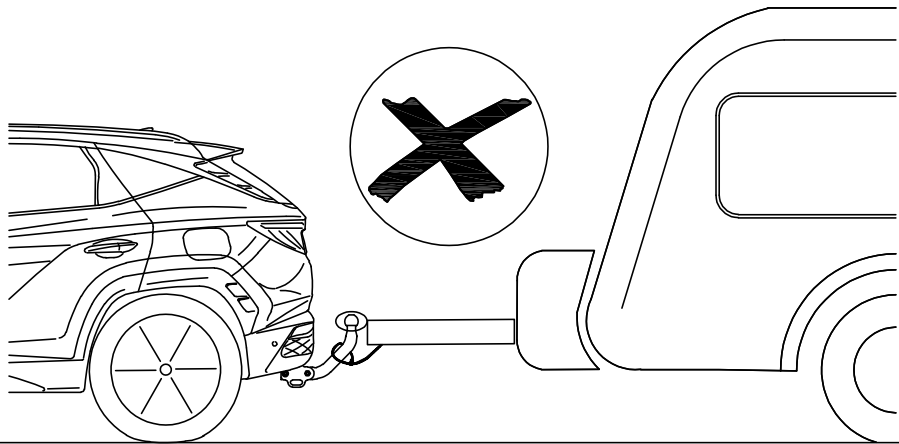

29

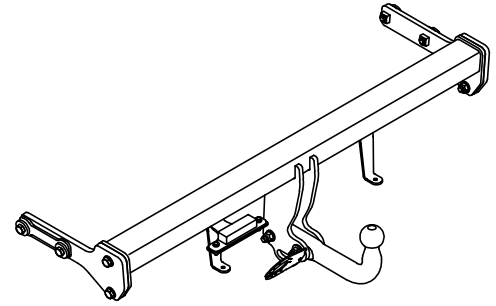
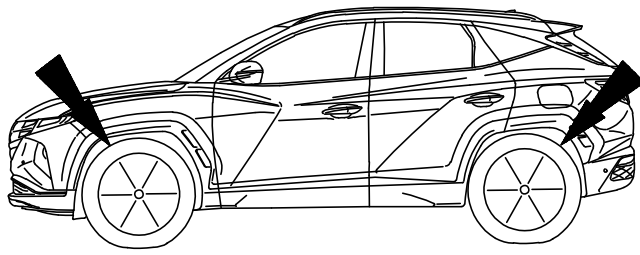

Best. Nr.: 3148 B

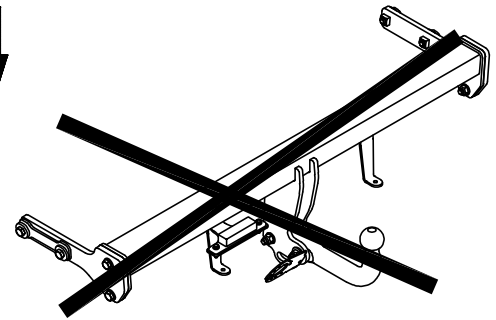
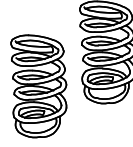
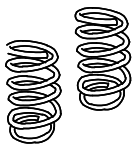
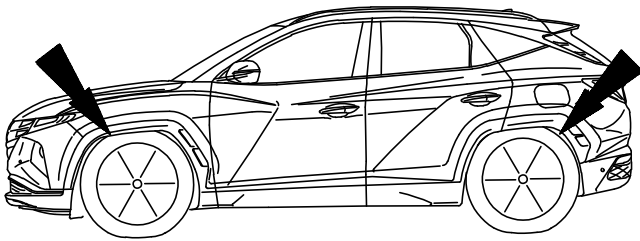
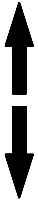

30

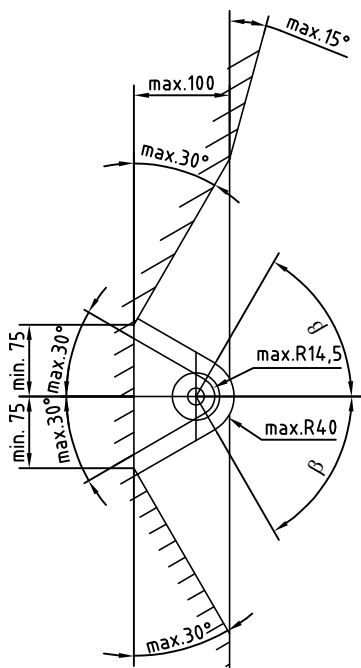
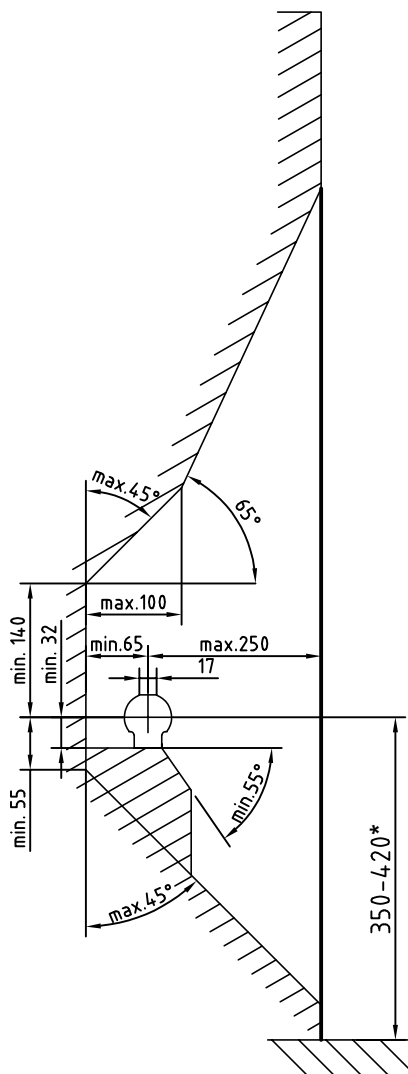

- D** Der Freiraum nach Anhang 7, Abbildung 25a und 25b der Richtlinie ECE-R 55 ist zu gewährleisten.
- CZ** Volný prostor ve smyslu Přílohy 7, obr. 25a a 25b směrnice ECE-R 55 musí být zaručen.
- DK** Det skal sikres, at der er spillerum i overensstemmelse med bilag 7, fig. 25a og 25b i henhold til direktiv ECE-R 55.
- E** Hay que garantizar el espacio libre conforme al anexo 7, fig. 25a y 25b de la directiva ECE-R 55.
- F** La zone de dégagement, selon l'annexe 7, figure 25a et 25b de la directive ECE-R 55, doit être assurée.
- FIN** Välyksen tulee täyttää ohjeen ECE-R 55 liitteen 7 kuvissa 25a ja 25b ilmoitetut vaatimukset.
- GB** Make sure to provide clearance according to appendix 7, figures 25a and 25b of the ECE-R 55 regulations.
- GR** Πρέπει να εξασφαλίζεται ο ελεύθερος χώρος σύμφωνα με το παράρτημα 7, σχήμα 25a και 25b της κοινοτικής οδηγίας ECE-R 55.
- H** Biztosítani kell az ECE-R 55 irányelv szerinti, 7. számú függelék, 25a. és 25b ábrákban jelölt szabad teret.
- I** Deve essere garantito lo spazio libero secondo l'allegato 7, figure 25a e 25b della normativa europea ECE-R 55.
- N** Det må sørges for fritt rom i samsvar med tillegg 7, figur 25a og 25b i direktiv ECE-R 55.
- NL** De vrije ruimte volgens supplement 7, afbeelding 25a en 25b van richtlijn ECE-R 55 moet gewaarborgd zijn.
- PL** Należy zapewnić wolną przestrzeń zgodnie z załącznikiem 7, rys. 25a i 25b, dyrektywy ECE-R 55.
- RUS** Оставлять свободное пространство согласно Приложению 7, рис. 25a и 25b Директивы ECE-R 55.
- S** Spelrummet enligt bilaga 7, bild 25a och 25b i riktlinje ECE-R 55, måste garanteras.

- D** * bei zulässigem Gesamtgewicht des Fahrzeuges
- CZ** * při celkové přípustné hmotnosti vozidla
- DK** * ved tilladt totalvægt for køretøjet
- E** * con peso total autorizado del vehículo
- F** * pour poids total en charge autorisé du véhicule
- FIN** * Ajoneuvon suurimmalla sallitulla kokonaispainolla
- GB** * at gross vehicle weight rating
- GR** * για το επιτρεπτό μικτό βάρος του οχήματος
- H** * A jármű megengedett összsúlyja esetén
- I** * per il peso complessivo ammesso del veicolo
- N** * ved kjøretøyets tillatte totalvekt
- NL** * bij toegestaan totaal gewicht van het voertuig
- PL** * przy dopuszczalnym ciężarze całkowitym pojazdu
- RUS** * при допустимом общем весе автомобиля
- S** * vid fordonets tillåtna totalvikt

- D** Die Anhängervorrichtung ist ein Sicherheitsteil und darf nur von Fachunternehmen montiert werden. Bei falscher Montage besteht schwere Unfallgefahr! Der deutsche Text dieser Anleitung ist bindend.
- CZ** Tažné zařízení je bezpečnostní součást, kterou smí montovat pouze odborné podniky. Při chybné montáži hrozí vážné nebezpečí nehody! Německý text tohoto návodu je závazný.
- DK** Anhængertrækket er en sikkerhedsdel og må kun monteres af autoriserede firmaer. Ved forkert montering er der fare for alvorlige uheld! Den tyske tekst i denne vejledning er bindende.
- E** La bola de enganche es un elemento de seguridad y sólo se debe permitir su montaje a personal cualificado. ¡En caso de montaje erróneo existe peligro de accidentes graves! Es vinculante el texto alemán de estas instrucciones.
- F** Le dispositif d'attelage est un équipement de sécurité et doit être mis en place exclusivement par un atelier spécialisé. Un montage incorrect représente un risque élevé d'accident! Le texte allemand de cette notice fait foi.
- FIN** Vetolaite on turvallisuuteen vaikuttava osa, jonka saa asentaa vain alan erikoisliike. Virheellinen asennus voi aiheuttaa vakavan onnettomuuden! Tämän ohjeen saksankielinen teksti on sitova.
- GB** A trailer hitch is a safety-critical part and may be fitted only by qualified companies. Improper assembly may result in a serious accident hazard! The German text of this instruction is binding.
- GR** Ο κοτσαδόρος είναι ένα εξάρτημα ασφαλείας και η τοποθέτηση του επιτρέπεται να γίνεται μόνο από εξειδικευμένο συνεργείο. Σε περίπτωση λάθους τοποθέτησης υπάρχει κίνδυνος σοβαρών ατυχημάτων! Το γερμανικό κείμενο αυτών των οδηγιών είναι δεσμευτικό.
- H** A vonószerkezet egy biztonságos felszerelés, amelyet csak szaküzem szerelhet fel. Helytelen szerelés súlyos balesethez vezethet! A német szerelési utasítás betartása kötelező.
- I** Il gancio di traino è un componente di sicurezza e deve essere montato esclusivamente da personale specializzato. In caso di montaggio errato sussiste il pericolo di incidenti gravi! È vincolante il testo tedesco di queste istruzioni.
- N** Tilhengerfestet er en sikkerhetskompont og skal monteres av fagbedrift. Det er stor fare for at det kan oppstå ulykker ved feil montering! Den tyske teksten i denne veiledningen er bindende.
- NL** De aanhanger is veiligheidsonderdeel en mag alleen door vakkundig personeel worden gemonteerd. Bij verkeerde montage bestaat ernstig gevaar voor ongevallen! De Duitse tekst van deze handleiding is bindend.
- PL** Hak holowniczy stanowi element bezpieczeństwa i może zostać zamontowany wyłącznie przez firmę specjalistyczną. W przypadku nieprawidłowego montażu istnieje poważne ryzyko wypadku! Tekst niniejszej instrukcji w języku niemieckim jest wiążący.
- RUS** Сцепное устройство - это узел, несущий предохранительные функции, и к его монтажу допускаются только специалисты. При неправильном монтаже грозит опасность тяжелых травм! Обязательным является немецкий текст данной инструкции.
- S** Dragkroken är en säkerhetskompont och bör endast monteras av kvalificerade tekniker. Vid felaktig montering föreligger risk för allvarliga olyckor! Den tyska texten i denna anvisning är bindande.