

i10 (AC3) MY 2020 -

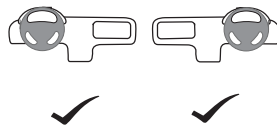

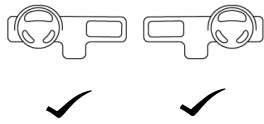

www.mobisparts.eu



99652ADE00



Reference picture



P 2



P 5

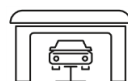

P 6



1,2 hours



(GB)

We expressly point out that assembly not carried out properly by a competent installer will result in cancellation of any right to damage compensation, in particular those arising by virtue of the product liability act. Contents of these kits and their fitting manuals are subject to alteration without notice, please ensure that these instructions are read and fully understood before commencing installation.

(NL)

De installatie moet worden uitgevoerd door een erkende, competente installateur. Incorrecte montage kan leiden tot het vervallen van elk recht op schadecompensatie, met name die met betrekking tot product aansprakelijkheid. De inhoud van deze kits en de installatiehandleidingen kunnen worden gewijzigd zonder kennisgeving. Zorg er voor, dat u deze instructies hebt gelezen en volledig begrijpt voordat u met de installatie begint.

(PL)

Pragniemy wyraźnie podkreślić, że nieprawidłowy montaż przeprowadzony przez niekompetentne osoby będzie podstawą rezygnacji z ewentualnego prawa do odszkodowania, w szczególności wynikających z mocy ustawy o odpowiedzialności za produkt. Zawartość opisywanych zestawów i instrukcje ich montażu mogą ulec zmianie bez uprzedzenia; przed rozpoczęciem instalacji należy zapoznać się z instrukcjami i upewnić się, że zostały w pełni zrozumiałe.

(F)

Nous tenons à insister tout particulièrement sur le fait que si ce produit n'est pas correctement assemblé par un technicien compétent, aucun droit de compensation ne sera recevable en cas de dommages, notamment les droits en vertu de la loi concernant la responsabilité à l'égard des produits. Le contenu de ce produit, ainsi que des guides de montage qui les accompagnent est sujet à modifications sans préavis; lisez attentivement ces instructions avant de procéder à l'installation.

(S)

Vi meddelar att montering, som inte görs fackmannamässigt, kommer att häva rätten till kompensation för skador, speciellt rättigheter enligt lagen om produktansvar. Innehållet i dessa satser och deras bruksanvisningar kan komma att ändras utan förvarning. Vänligen läs dessa anvisningar noga innan du påbörjar monteringen.

(SK)

Upozorňujeme, že inštalácia vykonaná nesprávne alebo nekompetentnou osobou, ruší všetky práva na kompenzáciu škôd, obzvlášť tých spôsobených poruchou produktu. Obsah týchto sád a návody na ich montáž podliehajú zmenám bez predchádzajúceho upozornenia. Prosím, uistite sa, že ste si pokyny pred inštaláciou prečítali a dostatočne ste im porozumeli.

(D)

Beachten Sie bitte, dass bei Schäden in Folge unsachgemäßen Einbaus sämtliche Garantieansprüche erlöschen. Das Recht zu Änderungen an Inhalt von Montagesatz und Einbauanleitung ohne Vorankündigung bleibt vorbehalten. Lesen Sie vor dem Einbau diese Anleitung sorgfältig durch.

(N)

Vi bemerker at montasje som ikke utføres korrekt, av en kompetent installatør, vil resultere i annullering av all rett til erstatning for enhver skade, spesielt de som oppstår av arten produktansvar. Innholdene i disse sett og deres monteringsanvisninger kan endres uten forvarsel. Vennligst påse at disse instruksjonene leses grundig og er forstått innen installasjonen startes.

(RO)

Vă atragem atenția că montajul efectuat incorect sau de către personal neautorizat duce la anularea oricărei drept de compensare a eventualelor daune produse utilizatorului. Conținutul acestor pachete precum și al instrucțiunilor de montaj pot fi modificate fără preaviz. Vă rugăm să vă asigurați că aceste instrucțiuni sunt citite și înțelese înainte de a începe instalarea.

(E)

Una vez más, hacemos hincapié en el hecho de que si este producto no es instalado correctamente por un técnico cualificado, se anulará cualquier derecho de compensación por posibles daños, especialmente los relativos a la legislación vigente sobre este tipo de productos. El contenido de los kits y sus correspondientes manuales de montaje están sujetos a posibles modificaciones sin previo aviso. Es importante que lea con atención todas las instrucciones y que las entienda perfectamente antes de iniciar la instalación.

(DK)

Det skal understreges, at montering, der udføres af en ikke-kvalificeret montør, medfører bortfald af enhver ret til erstatning særligt i forbindelse med erstatningskrav, der måtte opstå i kraft af loven om produktansvar. Sættenes indhold og monteringsvejledninger kan ændres uden varsel, og vejledningerne skal derfor læses og forstås, før monteringen påbegyndes.

(BG)

Изрично посочваме, че при монтиране, което не се осъществява правилно от компетентен монтьор, ще последва отмяна на всякакви права за обезщетение за нанесени вреди, по-специално тези, произтичащи въз основа на закона за отговорност за вреди. Съдържанието на тези комплекти и техните монтажни ръководства подлежат на изменения без предизвестие. Моля, уверете се, че инструкциите са прочетени и напълно разбрани преди започване на монтажната дейност.

(PT)

Salientamos expressamente que a montagem não realizada por um instalador competente resultará no cancelamento de quaisquer direitos a compensações por danos, particularmente dos resultantes ao abrigo da lei sobre responsabilidade de produtos. O conteúdo destes kits e os respetivos manuais de instalação estão sujeitos a alteração sem aviso prévio. Certifique-se de que estas instruções são lidas na íntegra e compreendidas antes de se iniciar a instalação.

(FIN)

Jos asennuksen suorittaa joku muu kuin pätevä ammattilainen, tämä kumoo asiakkaan oikeuden vahingonkorvauksiin, erityisesti sellaisiin, jotka perustuvat tuotevastuulakiin. Kiinnityssarjan sisältöä ja asennusohjeita voidaan muuttaa siitä etukäteen ilmoittamatta. Näihin ohjeisiin tulee perehtyä huolellisesti ennen asennuksen aloittamista.

(EST)

Juhime tähelepanu sellele, et ebakorrektnete ja ebapädeva paigaldaja tehtud montaaž tühistab õiguse esitada kahjunõudeid, eelkõige tootevastutusseaduse alusel esitatavaid nõudeid. Nende komplektide ja paigaldusjuhendite sisu võidakse ette teatamata muuta, mistõttu tuleb juhised enne paigalduse alustamist läbi lugeda ja neist täielikult aru saada.

(I)

Vi informiamo che, in caso di installazione scorretta e/o non eseguita da un installatore competente, il Cliente perderà ogni diritto a un eventuale rimborso danni e, specificamente, ogni diritto previsto dalle leggi sulla responsabilità di prodotto. I contenuti di questi kit e i relativi manuali di installazione sono soggetti a modifica senza preavviso. Si raccomanda di leggere attentamente e integralmente tali istruzioni e di sincerarsi di averle comprese prima di procedere all'installazione.

(CZ)

Upozorňujeme, že instalace provedená nesprávne nebo nekompetentní osobou, ruší veškerá práva na kompenzaci škod, obzvlášť tech způsobených poruchou produktu. Obsah těchto sad a návody na jejich montáž podléhají změnám bez předchozího upozornění. Prosím, ujistěte se, že jste si pokyny před instalací přečetly a dostatečně jim rozumíte.

(HR)

Izričito naglašavamo da će montaža koju ne provodi ovlašteni instalater rezultirati otkazivanjem svih prava na naknadu štete, osobito onih koja se temelje na zakonskim propisima o odgovornosti za proizvode. Sadržaj ovih kompleta i njihovih priručnika za pričvršćivanje podložni su izmjeni bez prethodne obavijesti, pažljivo pročitajte s razumijevanjem ove upute prije započinjanja s instalacijom.



www.mobisparts.eu



HU

Kifejezetten felhívjuk a figyelmét, hogy a nem megfelelően, hozzáértő szakember által végzett összeszerelés a kártérítésre vonatkozó valamennyi jog elvesztését eredményezi, különös tekintettel a termékgaranciáról szóló törvények biztosította jogokra. A készletek és a felhelyezési útmutatók tartalma külön értesítés nélkül változhat, ezért a szerelés megkezdése előtt mindenképp gondosan tanulmányozza át és értelmezze az utasításokat.

LAT

Mēs īpaši norādām uz to, ka gadījumos, kad aplimēšanu nebūs pareizi veicis kompetents tehniķis, jebkādas tiesības uz zaudējumu atlīdzību tiks anulētas, jo īpaši tādas, ko pamato produktu drošumatbīdības likums. Šo komplektu un to uzlīmēšanas rokasgrāmatu saturs var tikt mainīts bez iepriekšēja paziņojuma, lūdzu, nodrošiniet, lai pirms līmēšanas sākšanas šie norādījumi būtu izlasīti un pilnībā izprasti.

LIT

Mes aiškiai nurodome, kad, jei montavimas nėra tinkamai atliktas kompetentingo montuotojo, nesuteikiamos jokios teisės į žalos kompensavimą, ypač tos, kurios išplaukia iš gaminio atsakomybės akto. Šių rinkinių turinys ir jų įrengimo vadovai gali būti keičiami nepranešus, užtikrinkite, kad prieš pradėdant įrengimo darbus būtų perskaitytos ir visiškai suprastos šios instrukcijos.

GB

Both the vehicle and the workshop are required to have a temperature between 65° and 104°F.

F

Le véhicule et l'atelier doivent avoir une température comprise entre 18° et 40°C.

D

Die Temperatur von Fahrzeug und Werkstatt soll zwischen 18° and 40°C liegen.

E

Mantener el vehículo y el área de trabajo en un rango de temperaturas entre 18° y 40°C.

PT

Tanto o veículo como a oficina têm de estar a uma temperatura entre 18° e 40°C.

I

Sia il veicolo che l'officina dovranno avere una temperatura compresa tra 18° e 40°C.

NL

Zowel voertuig als werkplaats moeten een temperatuur hebben tussen 18° en 40°C.

S

Både fordonet samt verkstaden skall hålla en temperatur mellan 18° - 40°C.

N

Både kjøretøyet og verkstedet er nødvendig for å ha en temperatur mellom 18° og 40°C.

SER

Posebno ističemo da će montaža koju nije obavio kvalifikovani montažer, imati za posledicu poništavanje svih prava na obeštećenje, a posebno onog koje proističe iz odluke o odgovornosti za proizvod. Sadržaj ovih kompleta i pripadajućih uputstava podleže izmenama bez upozorenja, molimo vas da se postarate da se ova uputstva pročitaju i u potpunosti razumeju pre početka instalacije.

SVN

Izrecno opozarjamo, da bo montaža, ki ne bo izvedena ustrezno s strani pristojnega monterja, povzročila razveljavitev kakršnih koli pravic do odškodnine, zlasti tistih, ki izhajajo iz zakona o odgovornosti za izdelek. Vsebina kompletov in priložnikov za vgradnjo je predmet sprememb brez predhodnega obvestila. Prepričajte se, da bodo izvajalci pred pričetkom vgradnje navodila prebrali in razumeli.

UKR

Наголошуємо на тому, що роботи мають здійснюватися належним чином і виключно вповноваженим виконавцем. В іншому випадку будь-які права на відшкодування збитків, зокрема ті, які виникають згідно із законодавством про відповідальність виробника за якість продукції, вважаються недійсними. Вміст цих комплектів і відповідні інструкції можуть бути змінені без попередження. Не розпочинайте роботи, якщо ви не прочитали та не зрозуміли повною мірою ці інструкції.

ICE

Við bendum gagnert á að ef samsetningin er ekki almennilega gerð af aðila sem er með viðeigandi þjálfun getur rétturinn á skaðabótum vegna skemmda, sérstaklega skaðabótum varðandi reglur um vöruábyrgð, orðið ógildur. Innihald settanna og uppsetningarleiðbeiningar geta breyst án fyrirvara. Vinsamlegast tryggjið að þessar leiðbeiningarnar séu lesnar og fullur skilningur til staðar áður en uppsetning hefst.

GR

Θα πρέπει να τονιστεί ότι συναρμολόγηση που δεν πραγματοποιείται σωστά και από ειδικευμένο εγκαταστάτη οδηγεί σε ακύρωση των όποιων δικαιωμάτων αποζημίωσης έναντι ζημίας και ιδιαίτερα αυτών που προκύπτουν σύμφωνα με το νόμο περί ευθύνης προϊόντος. Τα περιεχόμενα αυτών των κιτ και τα εγχειρίδια τοποθέτησης υπόκεινται σε αλλαγές χωρίς προειδοποίηση. Βεβαιωθείτε ότι ο οδηγός αυτές έχουν διαβάσει και έχουν γίνει απολύτως κατανοητές προτού ξεκινήσετε την εγκατάσταση.

RUS

Обратите внимание, что при повреждениях, возникших в результате неправильного монтажа, истекают все виды гарантии, в частности, касающиеся закона, регулирующего ответственность за качество продукции. Производитель сохраняет за собой право на изменение содержания монтажного комплекта и инструкции по установке без предварительного уведомления. Внимательно прочитайте инструкцию перед началом установки.

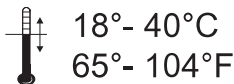

18° - 40°C
65° - 104°F

DK

Både bilen og værkstedet skal under hele arbejdet have en temperatur i mellem 18° og 40° grader C.

FIN

Toimenpiteen aikana tulee sekä ajoneuvon että asennustilan lämpötilan olla 18° ja 40°C asteen välillä.

CZ

Vozidlo i dílna by při instalaci měli být temperovány mezi 18° až 40°C.

PL

Temperatura nadwozia samochodu, jak i temperatura powietrza w warsztacie, muszą się mieścić w zakresie 18° - 40°C.

SK

Vozidlo, taktiež aj dielňa, by mali mať teplotu od 18° do 40°C.

RO

Temperatura din atelier și temperatura vehicului trebuie să se încadreze între 18° și 40°C.

BG

Необходимо е температурата на автомобила, както и на сервиза да бъде между 18°C и 40°C.

EST

Nii sõiduki kui ka töökoja temperatuur peab olema vahemikus 18° - 40°C.

HR

Temperatura u vozilu i radionici treba biti između 18° i 40°C.

HU

A jármű és a műhely hőmérsékletének egyaránt 18°C és 40°C közé kell esnie.

LAT

Gan transportlīdzekļa temperatūrai, gan temperatūrai darbnīcā jābūt starp 18° un 40°C.

LIT

Tiek mašinos, tiek dirbtuvių aplinkos temperatūra turi būti nuo 18° iki 40°C.

SER

Zahteva se da i vozilo i radionica budu na temperaturi između 18° i 40°C.

SVN

Temperatura vozila in delavnice mora biti med 18°C in 40°C.

UKR

Температура автомобіля та повітря в майстерні має бути в межах 18° - 40°C.

ICE

Hitastig ökutækisins og verkstæðisins á að vera 18° - 40°C.

GR

Τόσο το όχημα όσο και το συνεργείο θα πρέπει να έχουν θερμοκρασία μεταξύ 18° και 40°C.

RUS

Температура автомобиля и помещения должна быть от 18° до 40°C.

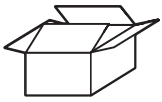
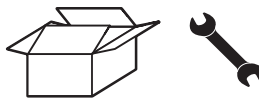

A 40cm

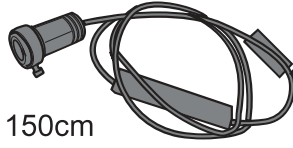

B 150cm

Control sticker
99652ADE00

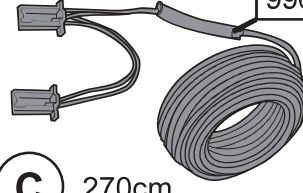

C 270cm

Control sticker
99652ADE00

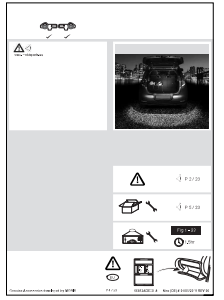

D		E		F		G	
1x	Ø 19 mm	2x		10x		10x	

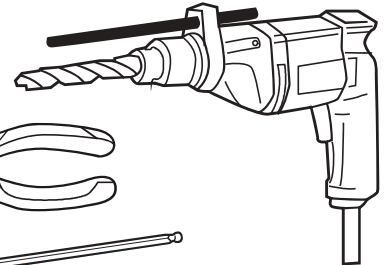
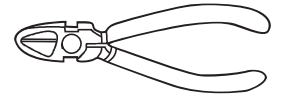
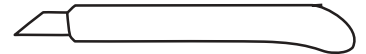
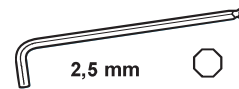
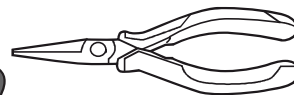
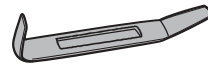
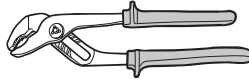
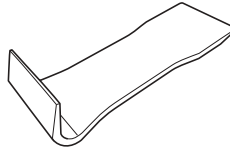
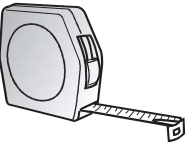
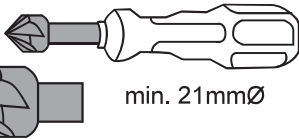
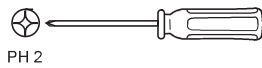

18° - 40°C
65° - 104°F

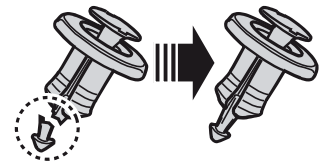

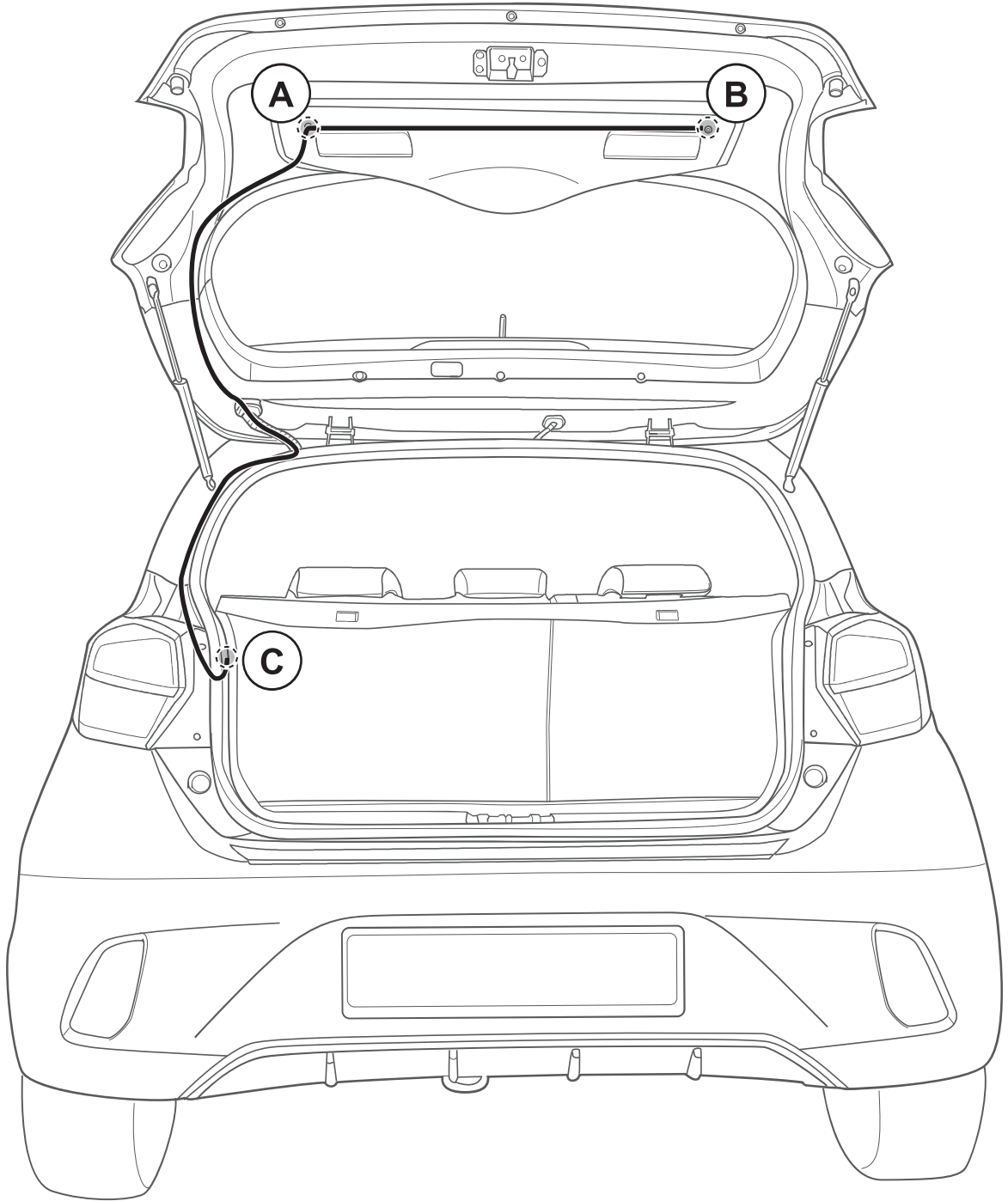

ROUTING

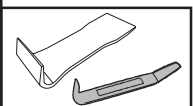
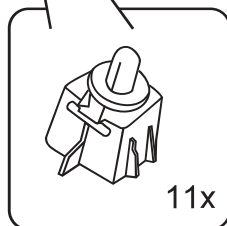
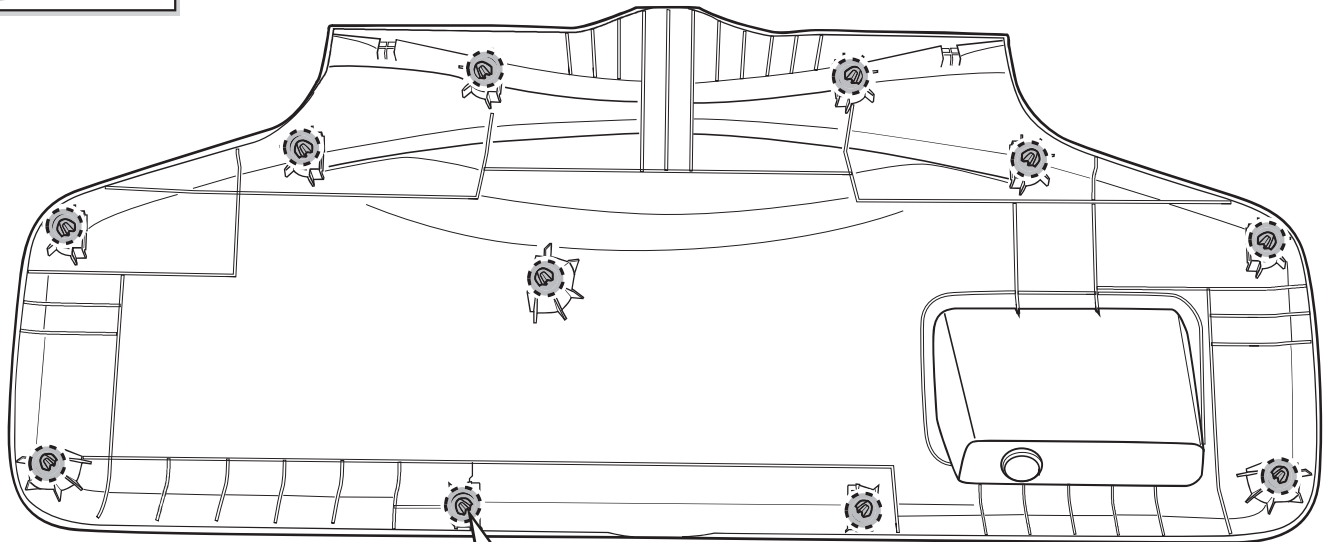
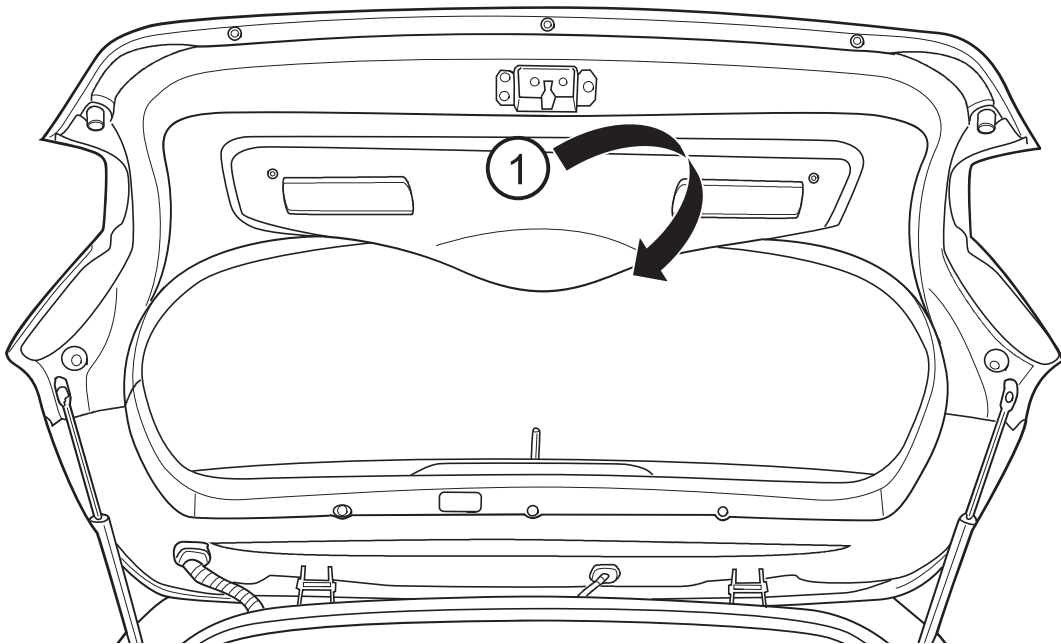

Fig 1

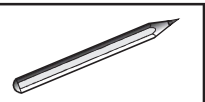
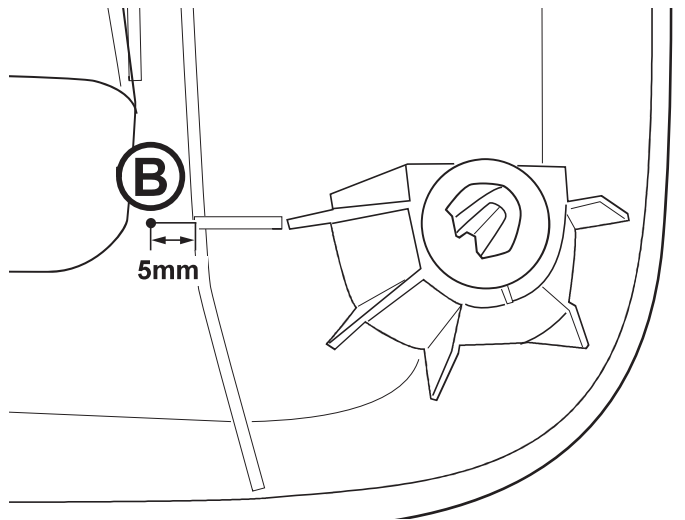
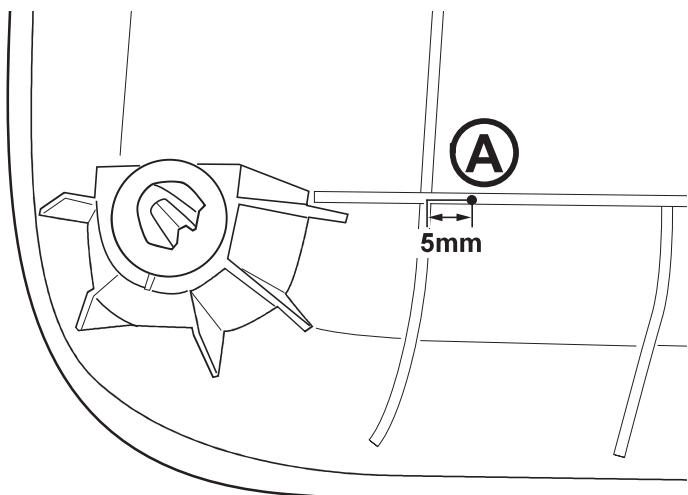
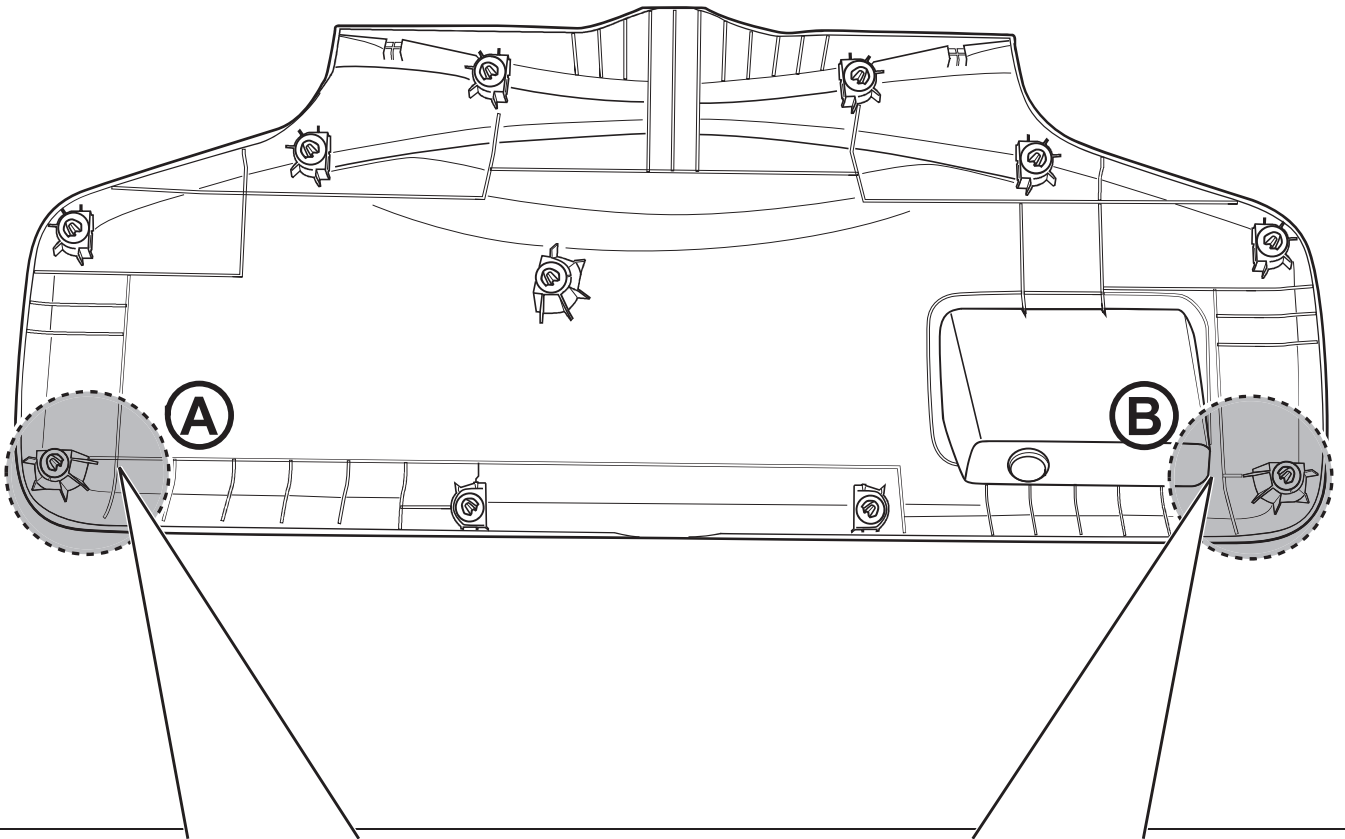
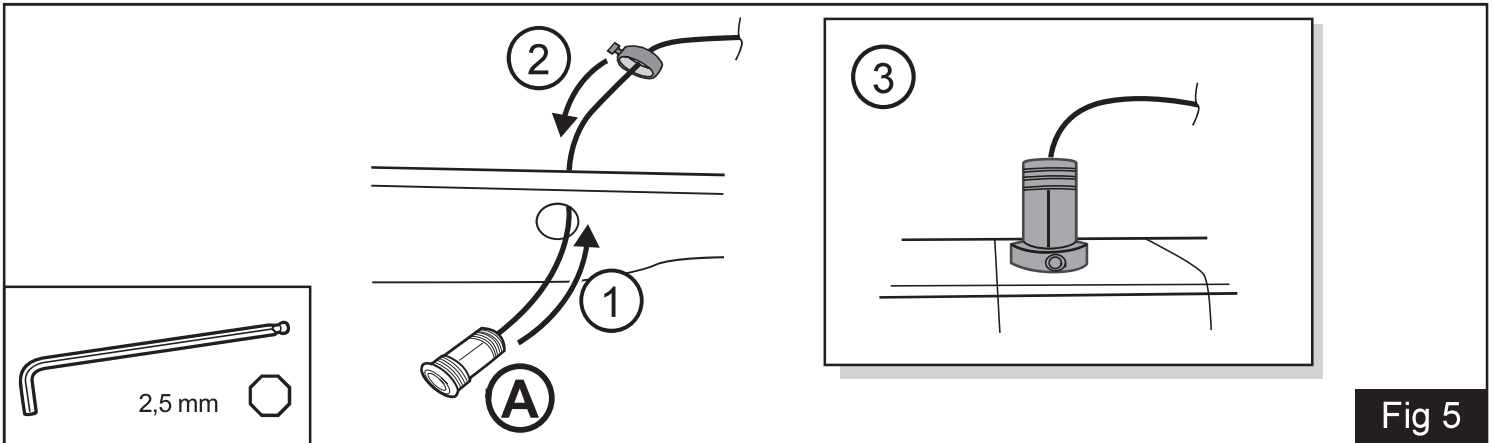
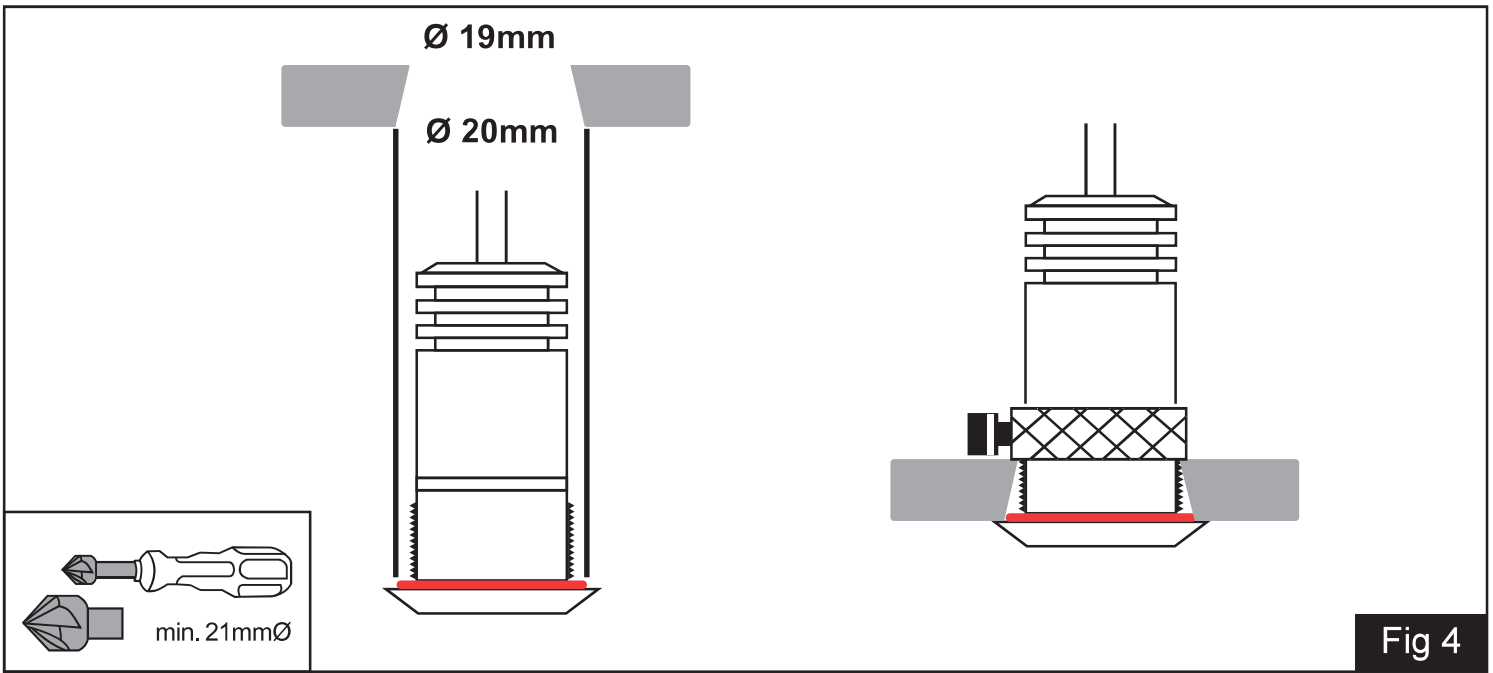
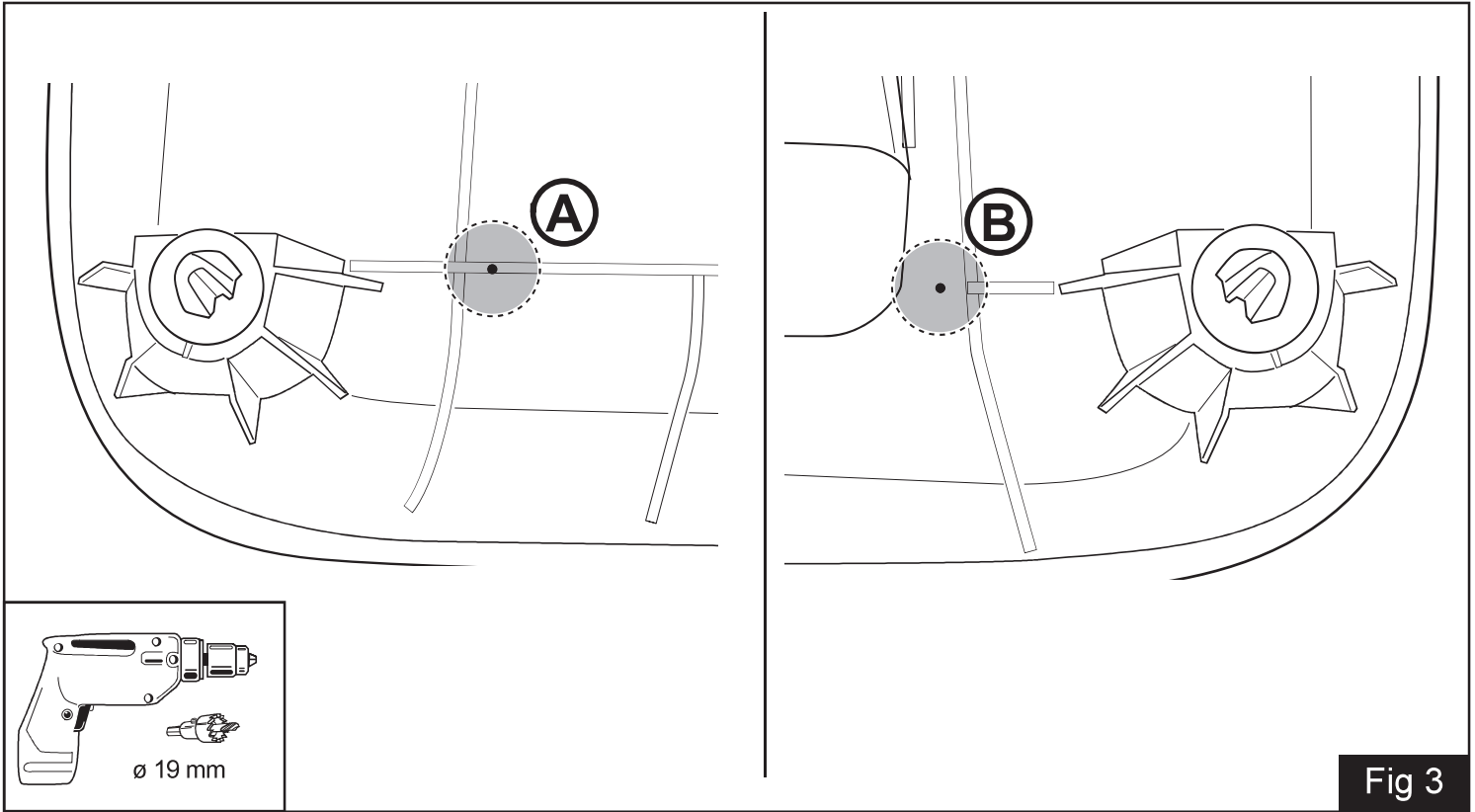
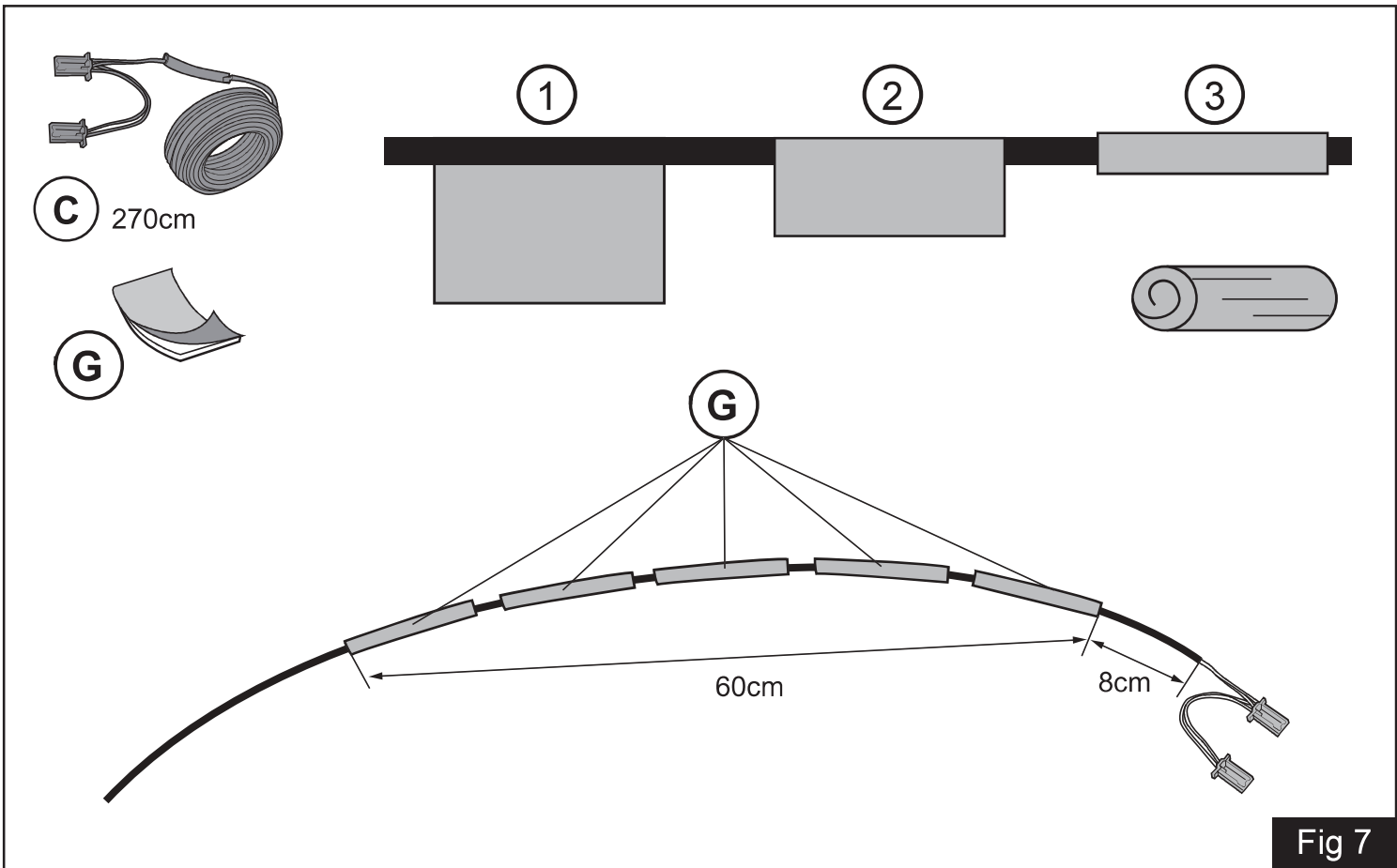
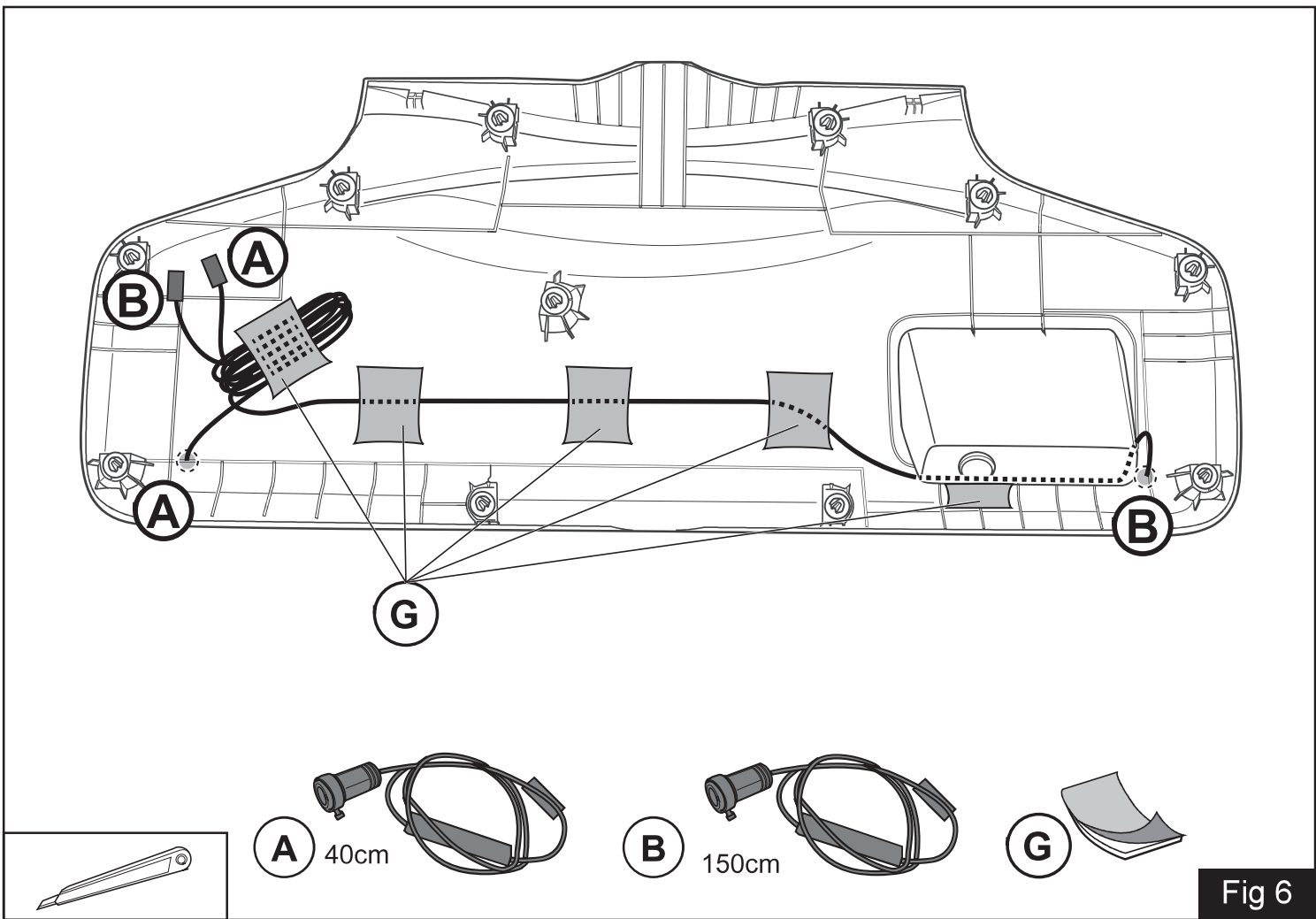

Fig 2





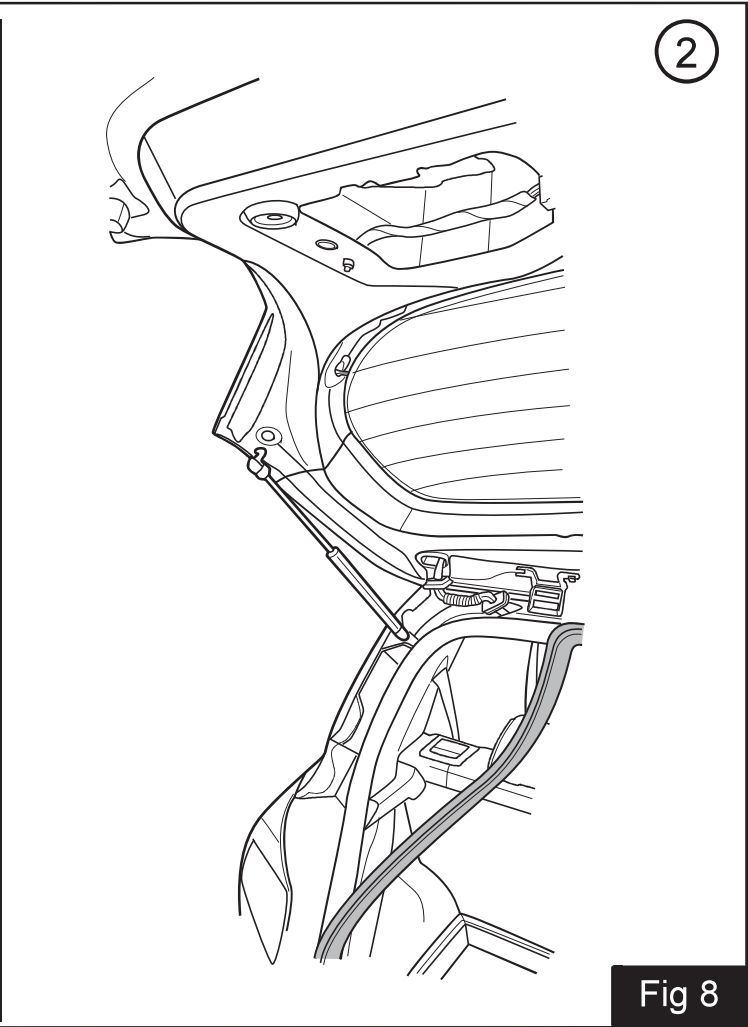
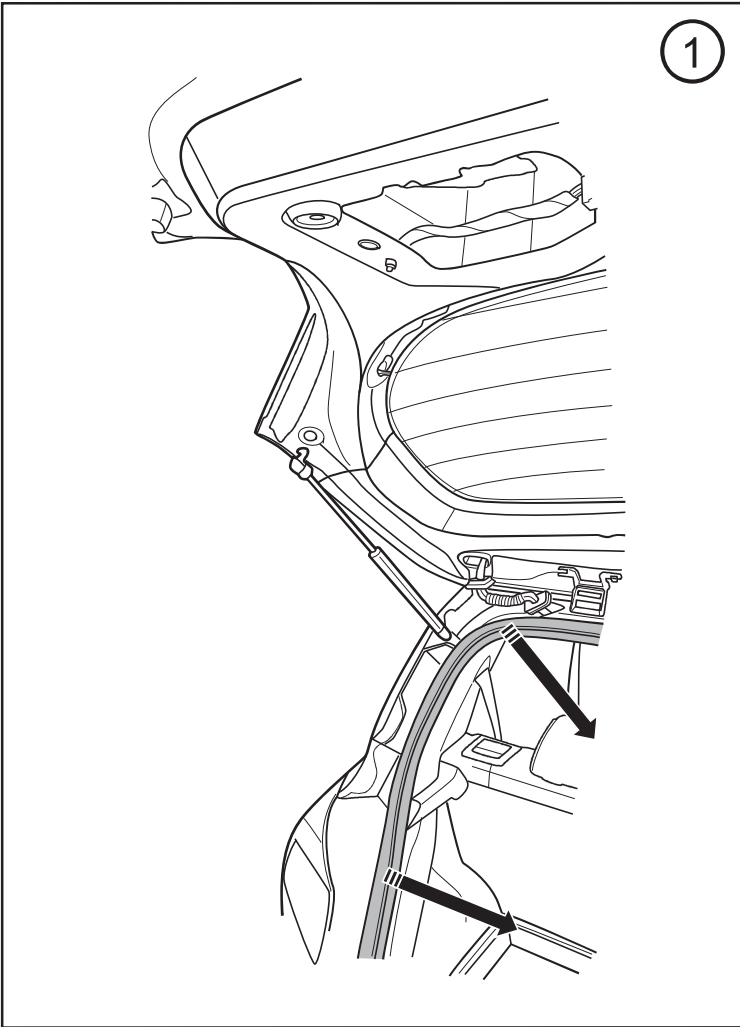

Fig 8

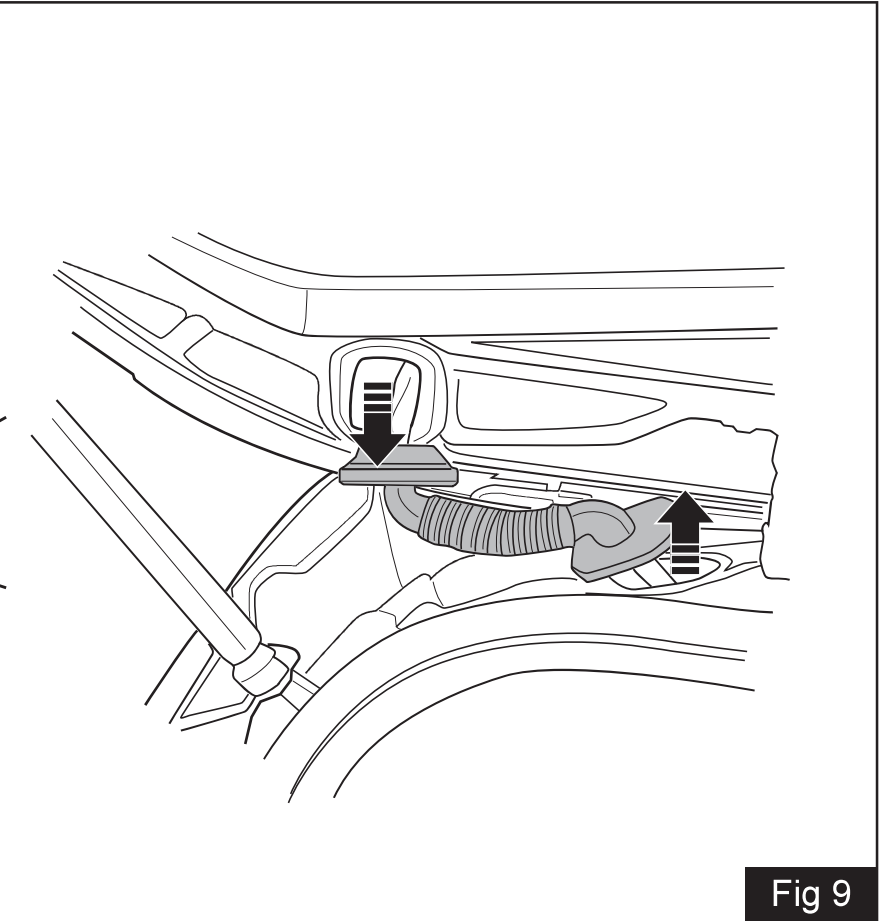
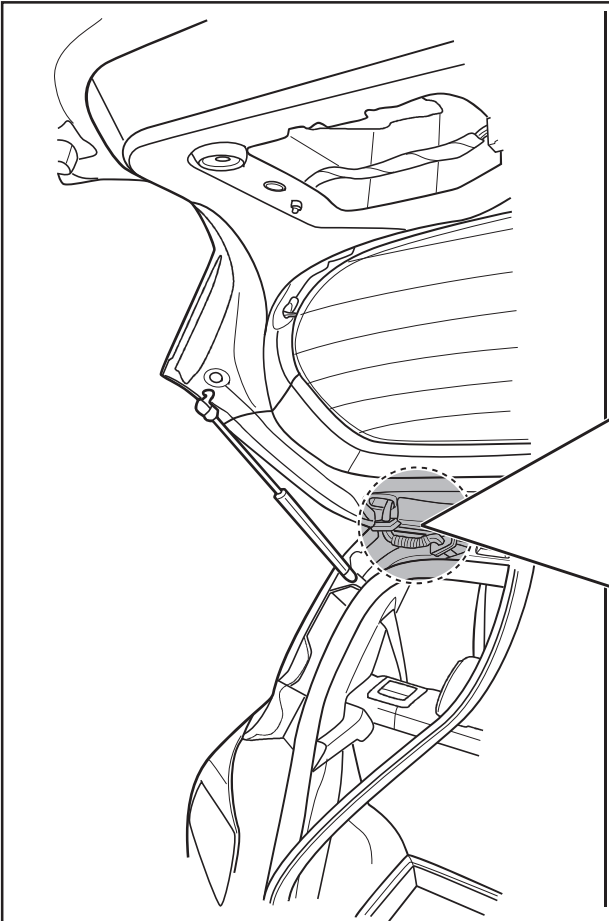
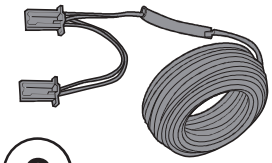

Fig 9



C 270cm

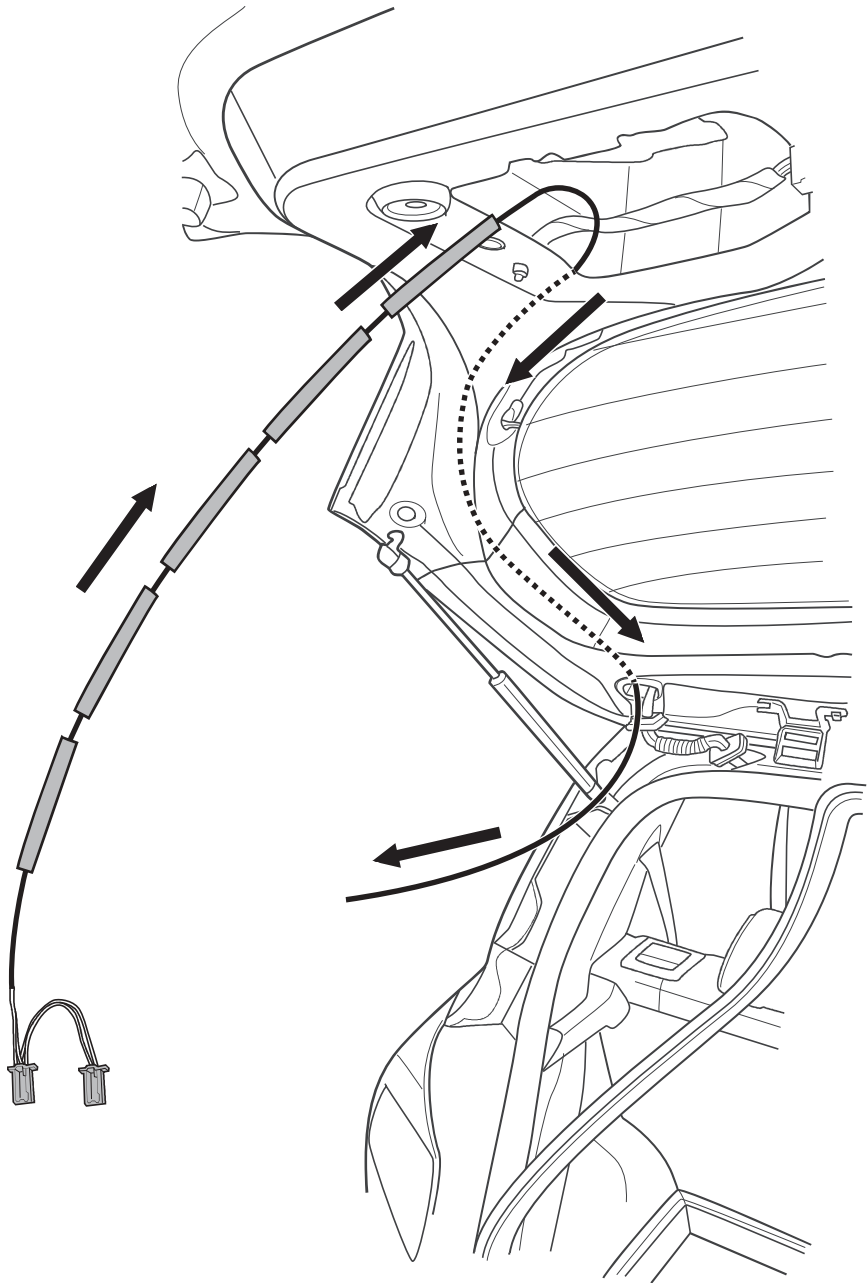
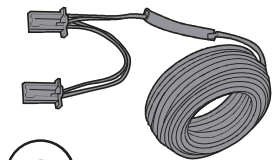
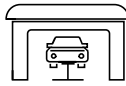
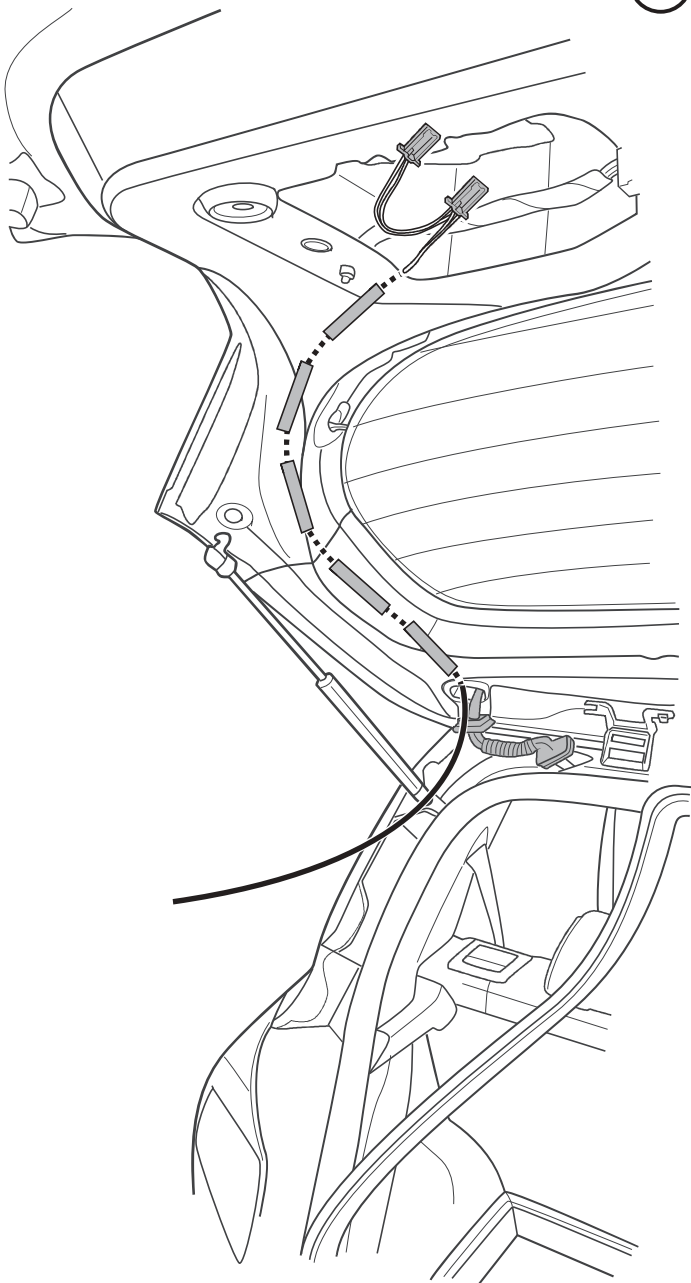

Fig 10



C 270cm

1



2

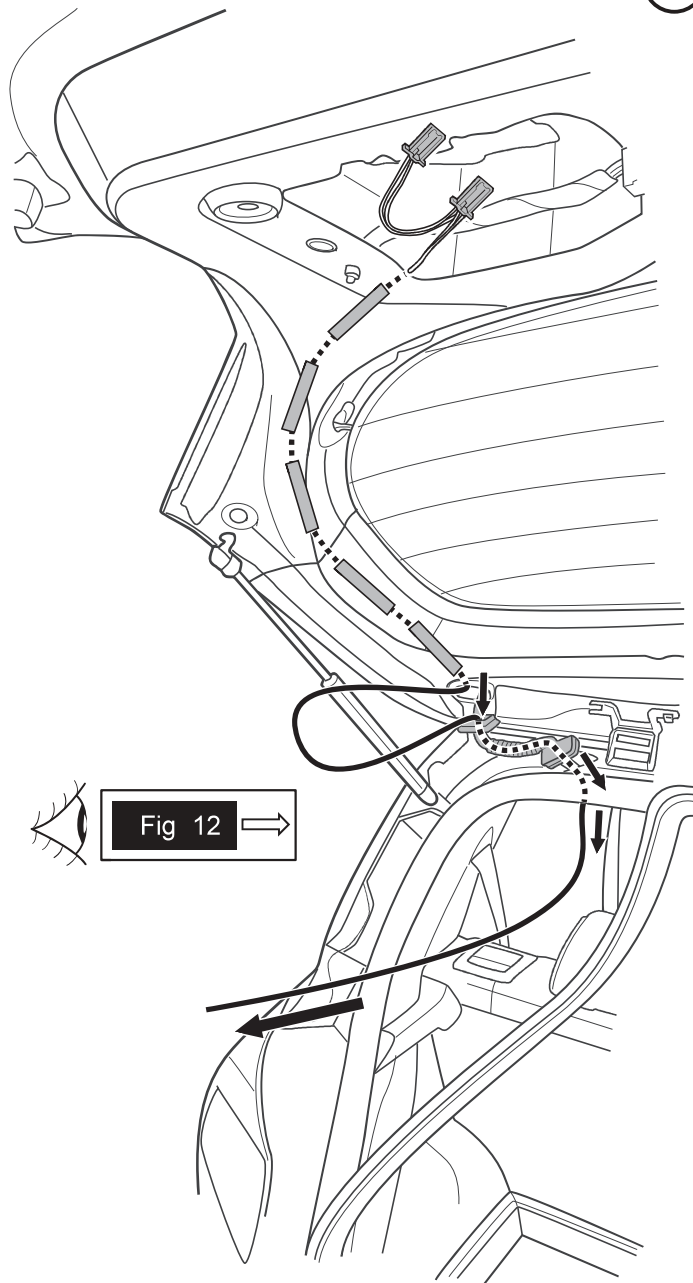

Fig 12 →

Fig 11





①



Ⓒ

②

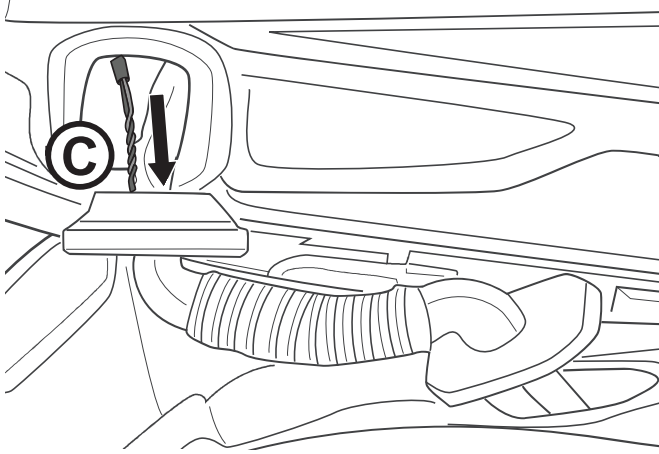

③

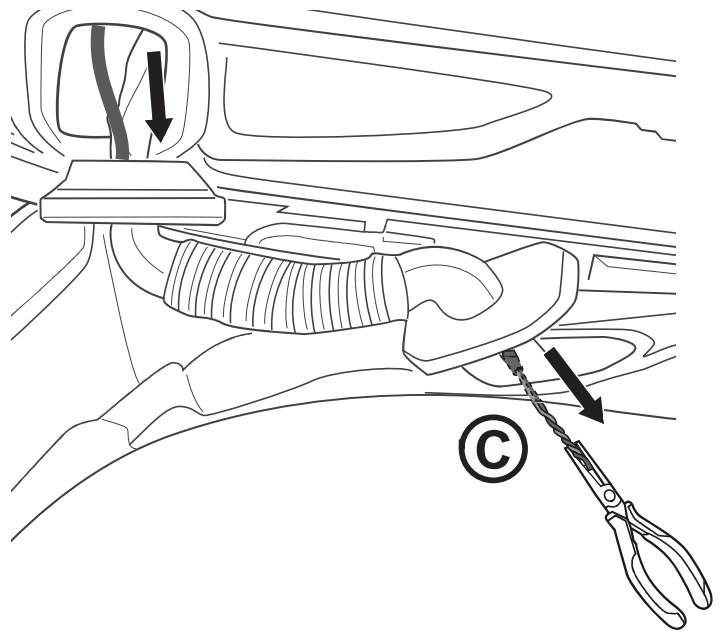

④

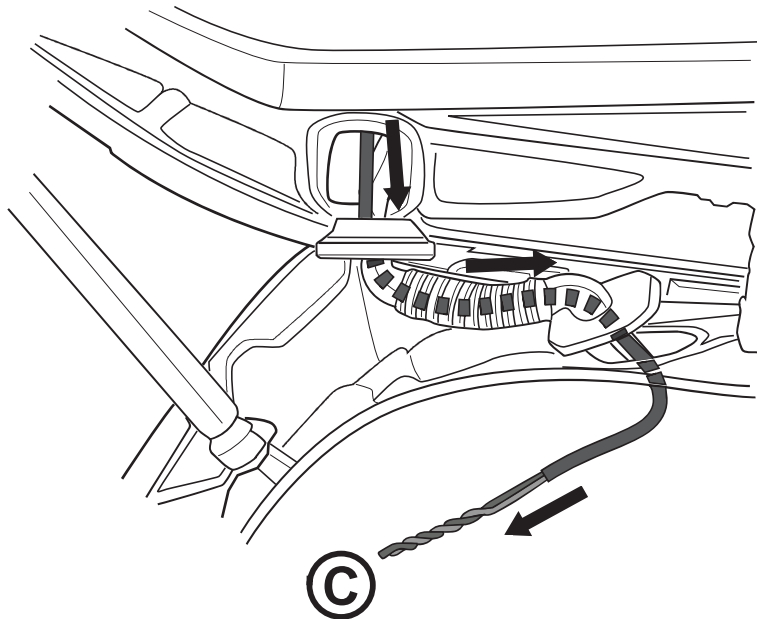

Fig 12

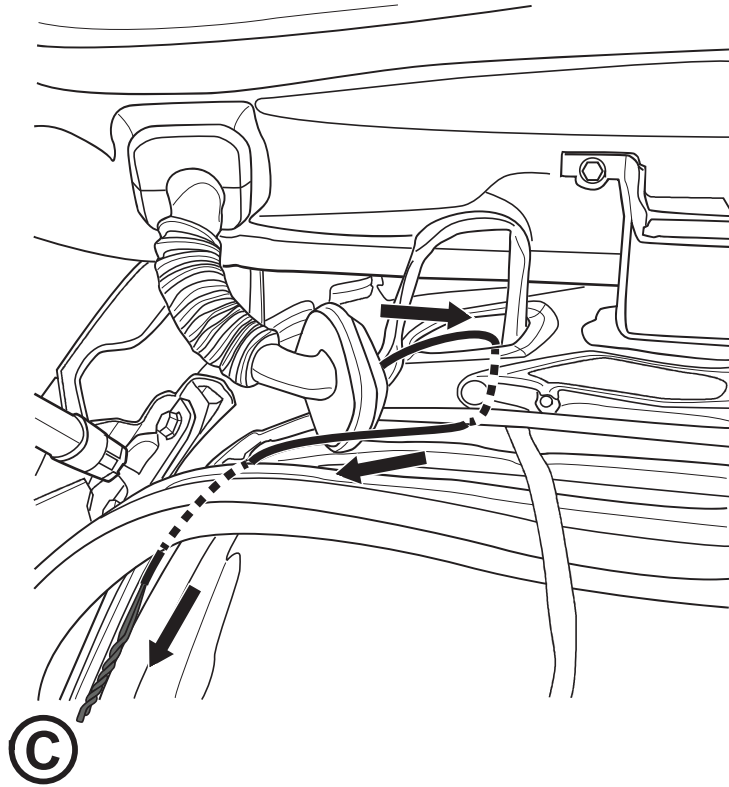

Fig 13

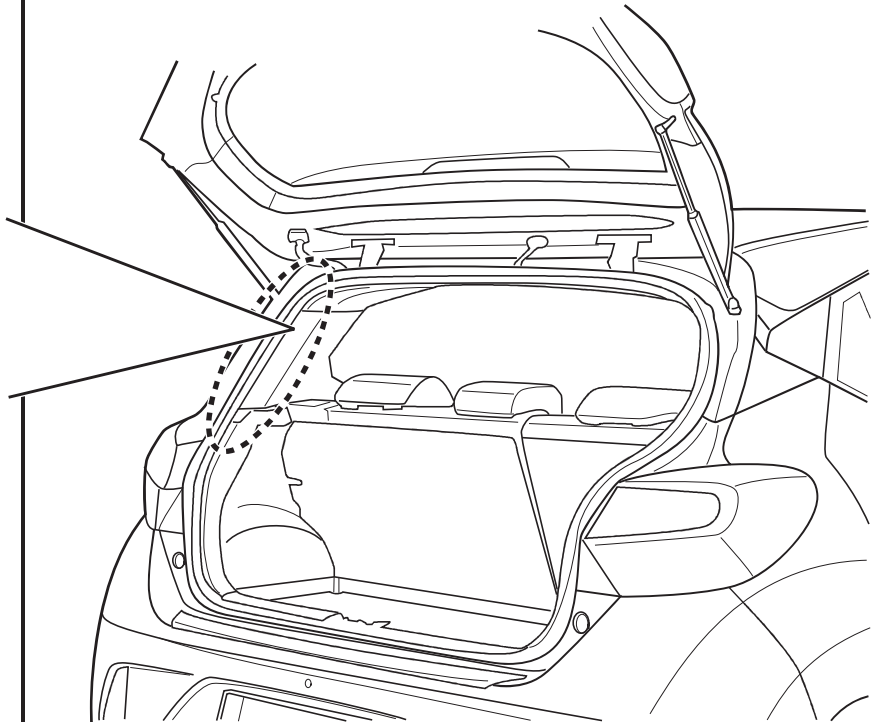
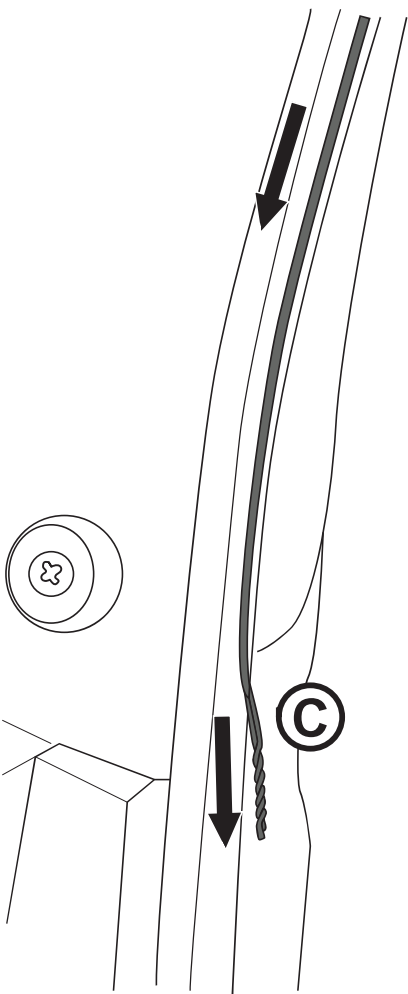

Fig 14

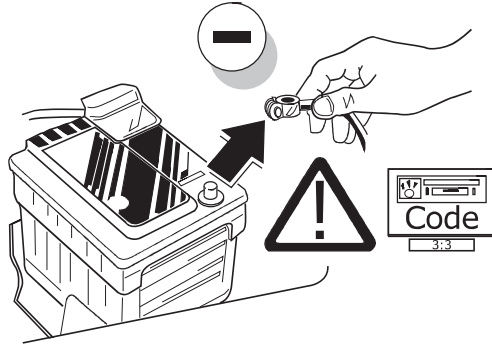
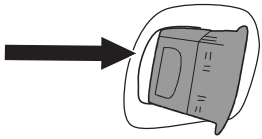

Fig 15

①



②

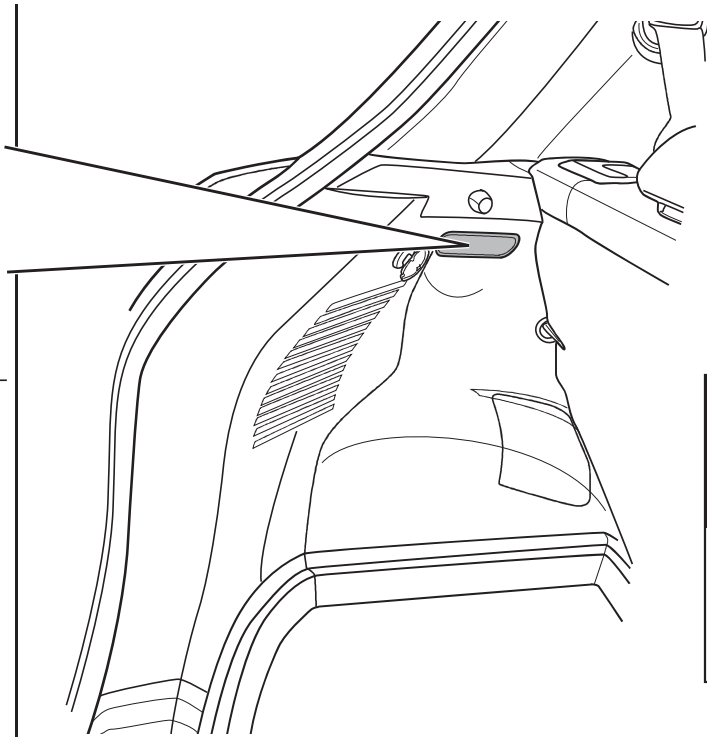
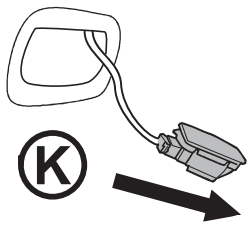

Fig 16

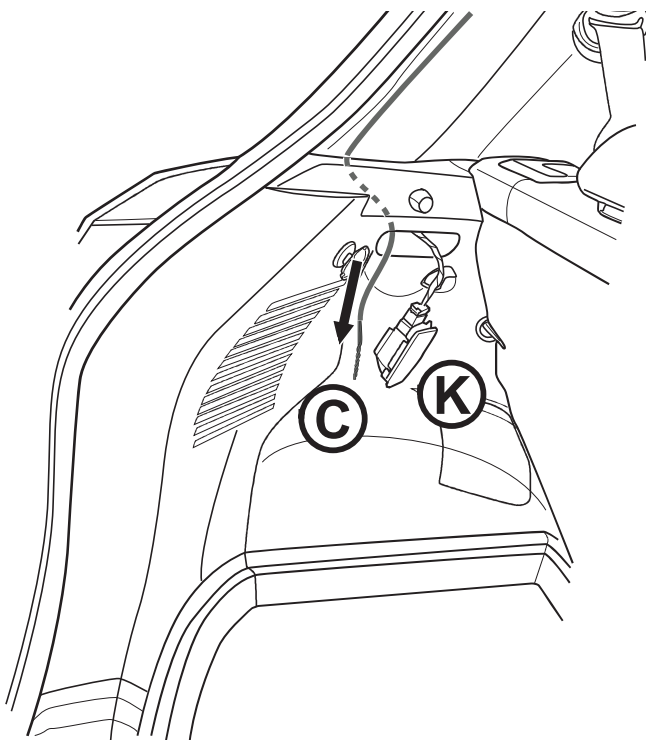
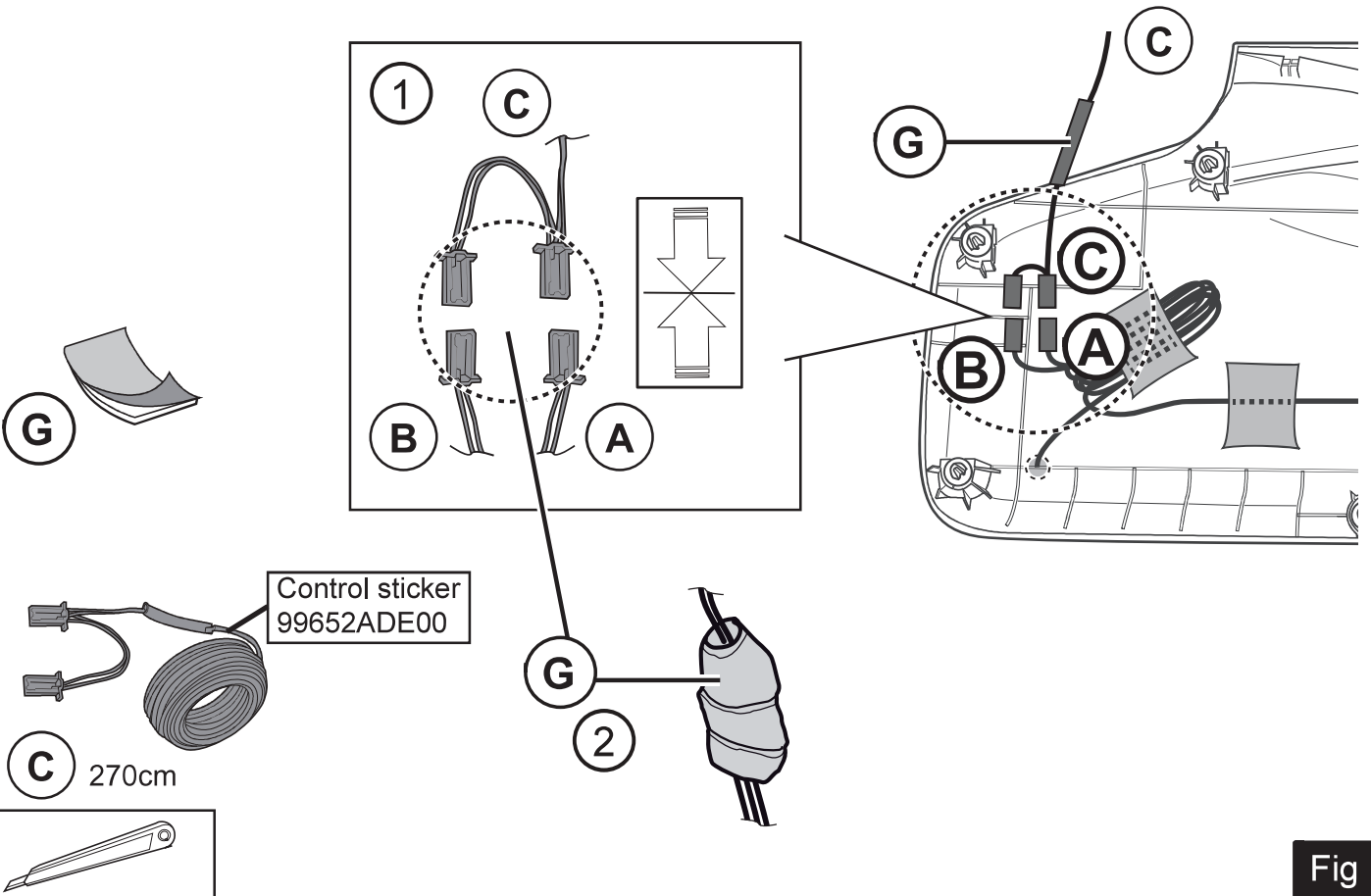
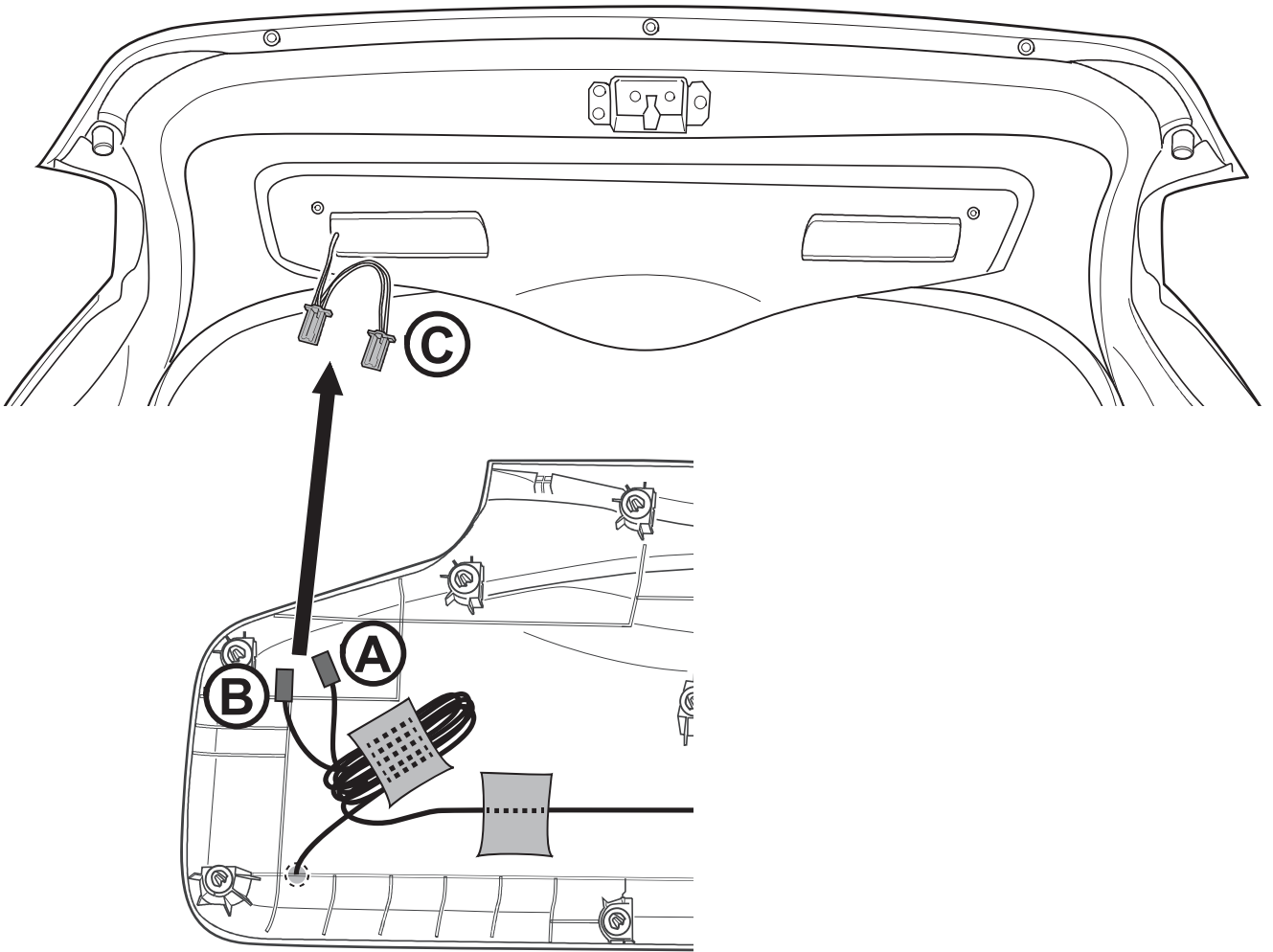

Fig 17



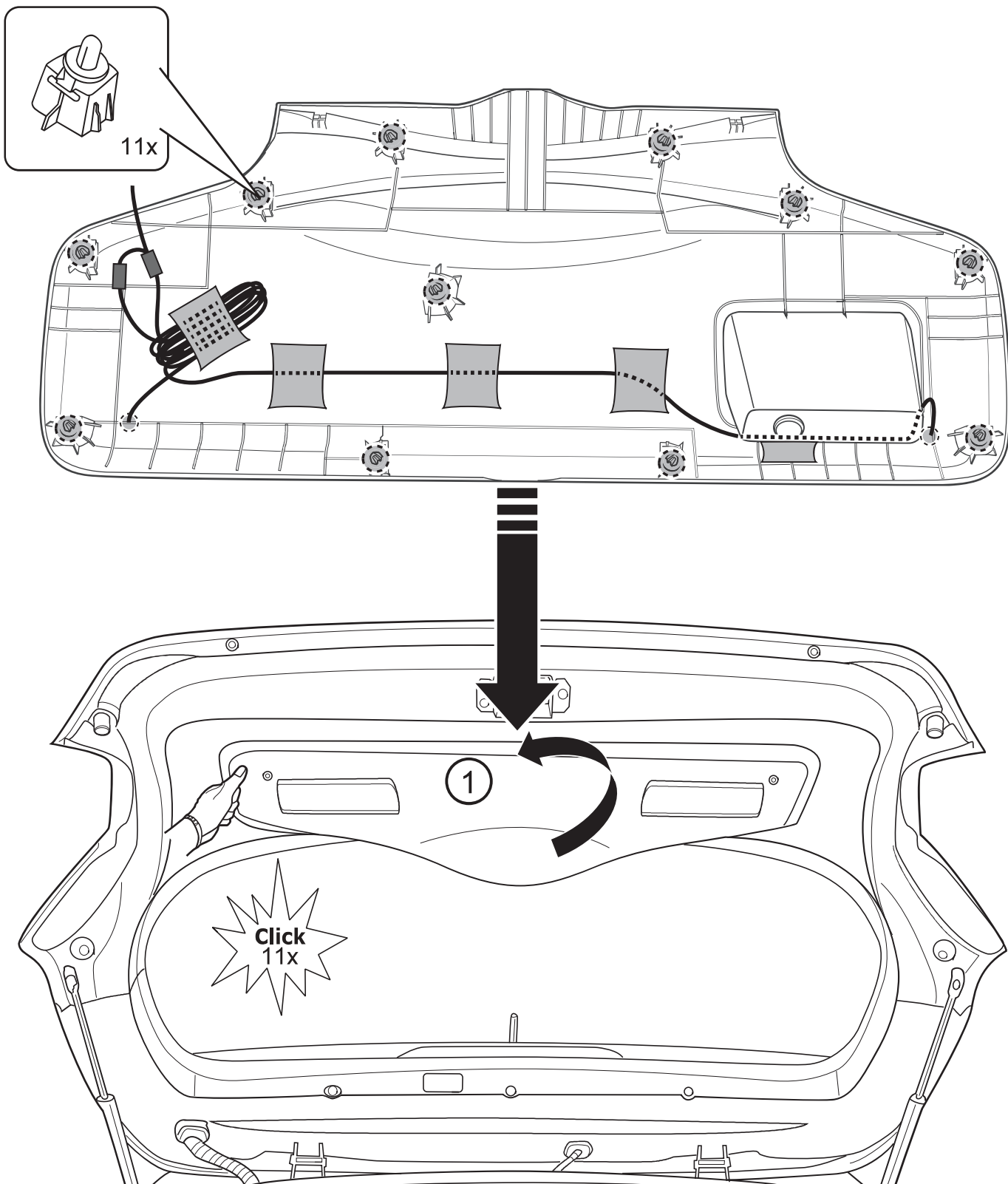
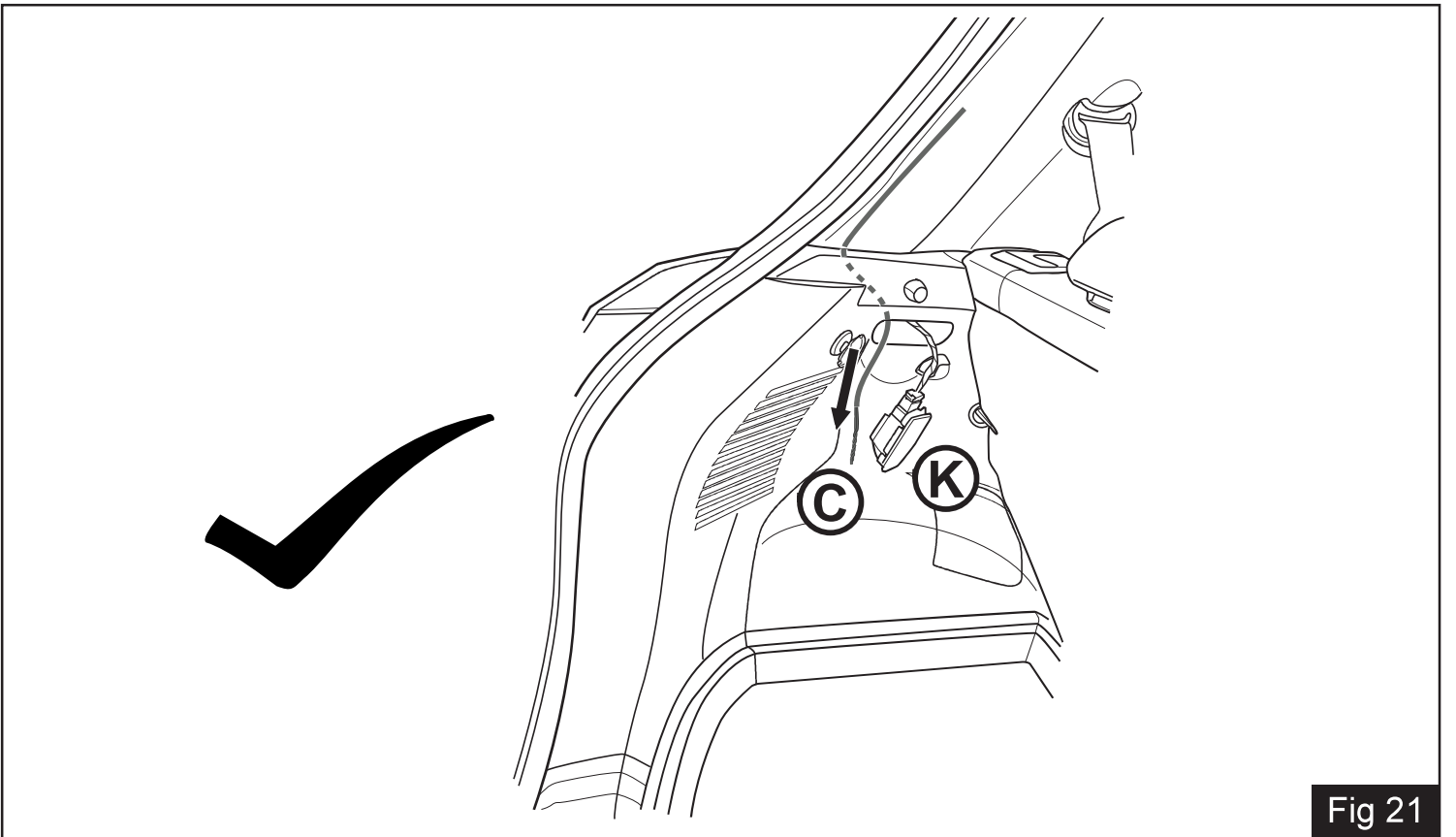
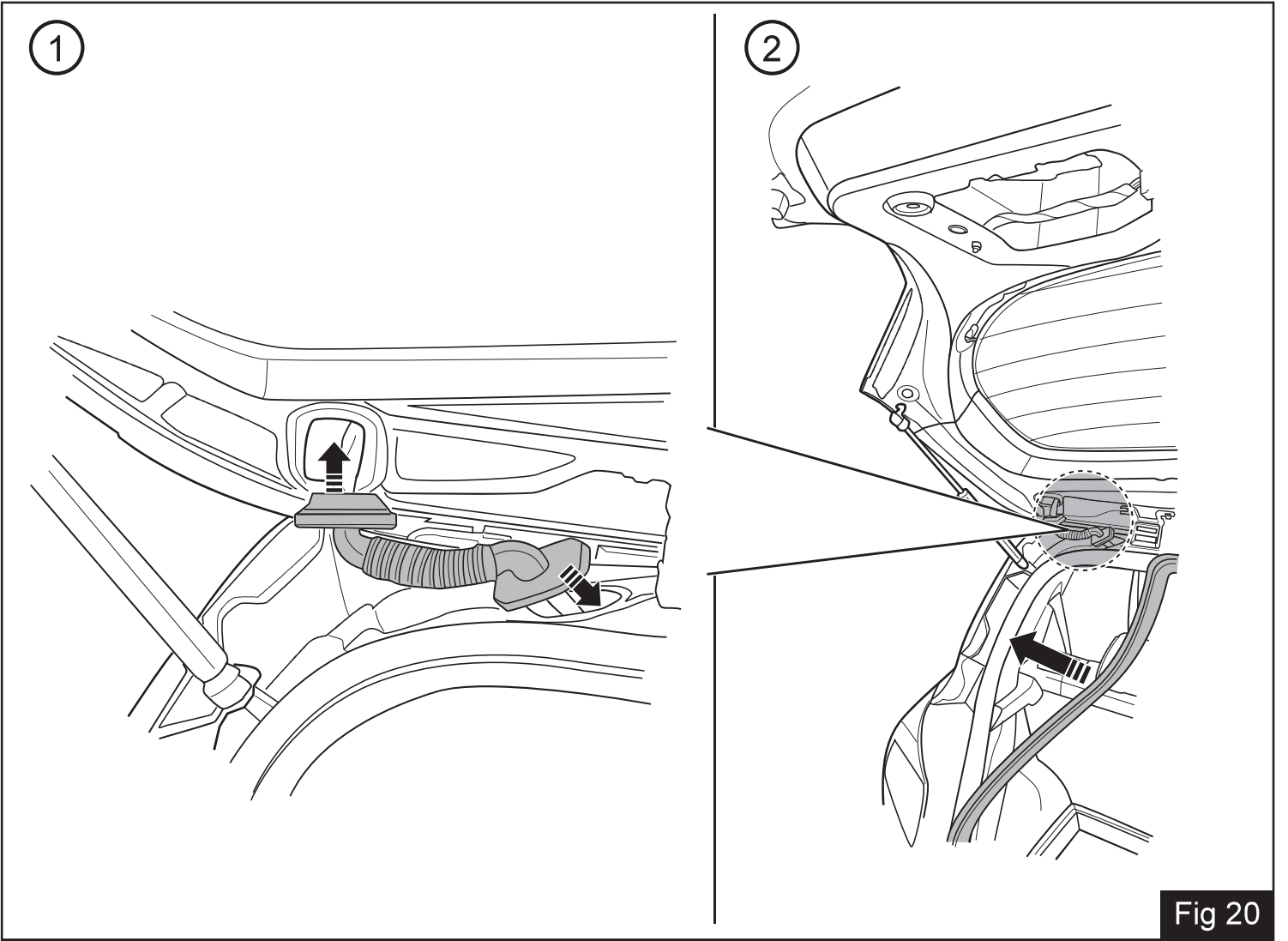

Fig 19





Example: Luggage lamp

A

Global Service Way | VIN | NLHDN51EJLZ000061 | Detail View | Change Language | Privacy Notice

Model ID : i10(AC3) | Model Year : 2020 | Engine : G 1.2 MPI KAPPA

Shop Manual | **ETM** | DTC Guide | Symptom | Component | Body Repair | SST | OVERHAUL | Owners Manual

My Page | Logout | Component Search (ISO 15031-2)

Link Site | Language: English | Model: Commercial | Year: Year

B

Shop Manual | **ETM** | DTC Guide | Symptom | Component | Body Repair | SST | OVERHAUL | Owners Manual

ETM

ETM | Passenger | English | i10(AC3) | 2020 | G 1.2 MPI KAPPA | GO

C

Global Service Way | VIN | NLHDN51EJLZ000061 | Change Language | Privacy Notice

Model ID : i10(AC3) | Model Year : 2020 | Engine : G 1.2 MPI KAPPA

Shop Manual | **ETM** | DTC Guide | Symptom | Component | Body Repair | SST | OVERHAUL | Owners Manual

ETM

ETM | Passenger | English | i10(AC3) | 2020 | G 1.0 T-GDI KAPPA | GO

G 1.0 T-GDI KAPPA

- General
- Component Locations
- Components Index
- Connector View
- Harness Layout
- Schematic Diagrams**
- Body Electrical System
 - A/V & Navigation
 - Audio System
 - Auto Lights
 - Back-Up Lamps
 - Cigarette Lighter (Power Outlet) System
 - Courtesy & Trunk Lamps**
 - Schematic Diagrams
 - Data Link Details
 - Daytime Running Lights (DRL)
 - Defogger System
 - Fog Lamps
 - Head Lamp Leveling Device (HLLD) System
 - Head Lamps
 - Horn
 - Illuminations
 - Indicator & Gauges
 - Integrated Body Control Unit (IBU)
 - Intelligent Power Switch (IPS) System
 - Keyless Entry & Burglar Alarm System

2020 > G 1.0 T-GDI KAPPA > G 1.0 T-GDI KAPPA > Schematic Diagrams > Body Electrical System > Courtesy & Trunk Lamps

Courtesy & Trunk Lamps (3) | SD929-3

W/O IBU (1/2)

W/O E-Call

W/O E-Call

W/O E-Call

To IPS Control Module (SD929-4)

Fig 22



	BK	BN	BU	GY	GN	WH	YE	OG	PE	PI	RD
DE	Schwarz	Braun	Blau	Grau	Grün	Weiß	Gelb	Orange	Violett	Rosa	Rot
FR	Noir	Marron	Blue	Gris	Vert	Blanc	Jaune	Orange	Violet	Rose	Rouge
NL	Zwart	Bruin	Blauw	Grijs	Groen	Wit	Geel	Oranje	Paars	Roze	Rood
GB	Black	Brown	Blue	Grey	Green	White	Yellow	Orange	Purple	Pink	Red
ES	Negro	Marrón	Azul	Gris	Verde	Blanco	Amarillo	Naranja	Morado	Rosa	Rojjo
IT	Nero	Marrone	Blu	Grigio	Verde	Bianco	Giallo	Arancione	Viola	Rosa	Rosso
SE	Svart	Brun	Blå	Grå	Grön	Vit	Gul	Orange	Lila	Rosa	Röd
CZ	Černá	Hnědá	Modrá	Šedá	Zelená	Bílá	Žlutá	Oranžová	Fialová	Růžová	Červená
DK	Sort	Brun	Blå	Grå	Grøn	Hvid	Gul	Orange	Lilla	Pink	Rød
FI	Musta	Ruskea	Sininen	Harmaa	Vihreä	Valkoinen	Keltainen	Oranssi	Purppura	Vaaleanpunainen	Punainen
GR	Μαύρο	Καφέ	Μπλε	Γκρι	Πράσινο	Λευκό	Κίτρινο	Πορτοκαλί	Μοβ	Ροζ	Κόκκινο
NO	Svart	Brun	Blå	Grå	Grønn	Hvit	Gul	Oransje	Lilla	Rosa	Rød
PL	Czarny	Brazowy	Niebieski	Szary	Zielony	Biały	Żółty	Pomarańczowy	Purpurowy	Różowy	Czerwony
RU	черный	Čierna	синий	серый	зеленый	белый	желтый	оранжевый	пурпурный	розовый	красный
SK	Čierna	Čierna	Modrá	Sivá	Zelená	Biela	Žltá	Oranžová	Fialová	Ružová	Červená
RO	Negru	Maro	Albastru	Grey	Verde	Alb	Galben	Portocale	Violet	Roz	Roşu

COLOURTABLE

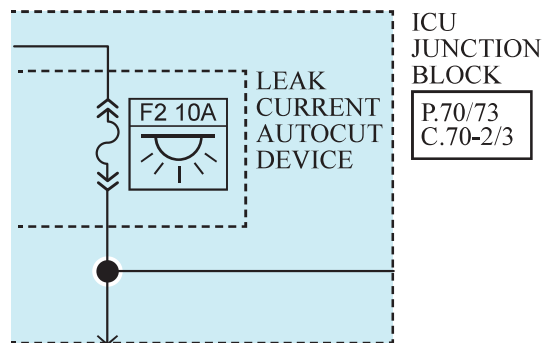

58 ICU-B

0.3Y

YE →

0.3Y

1 F13

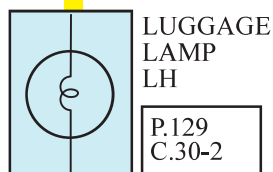

3 F13

0.3B/O

BK/OG →



To IPS
Control Module
(SD929-4)

L & R



Fig 23

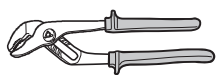
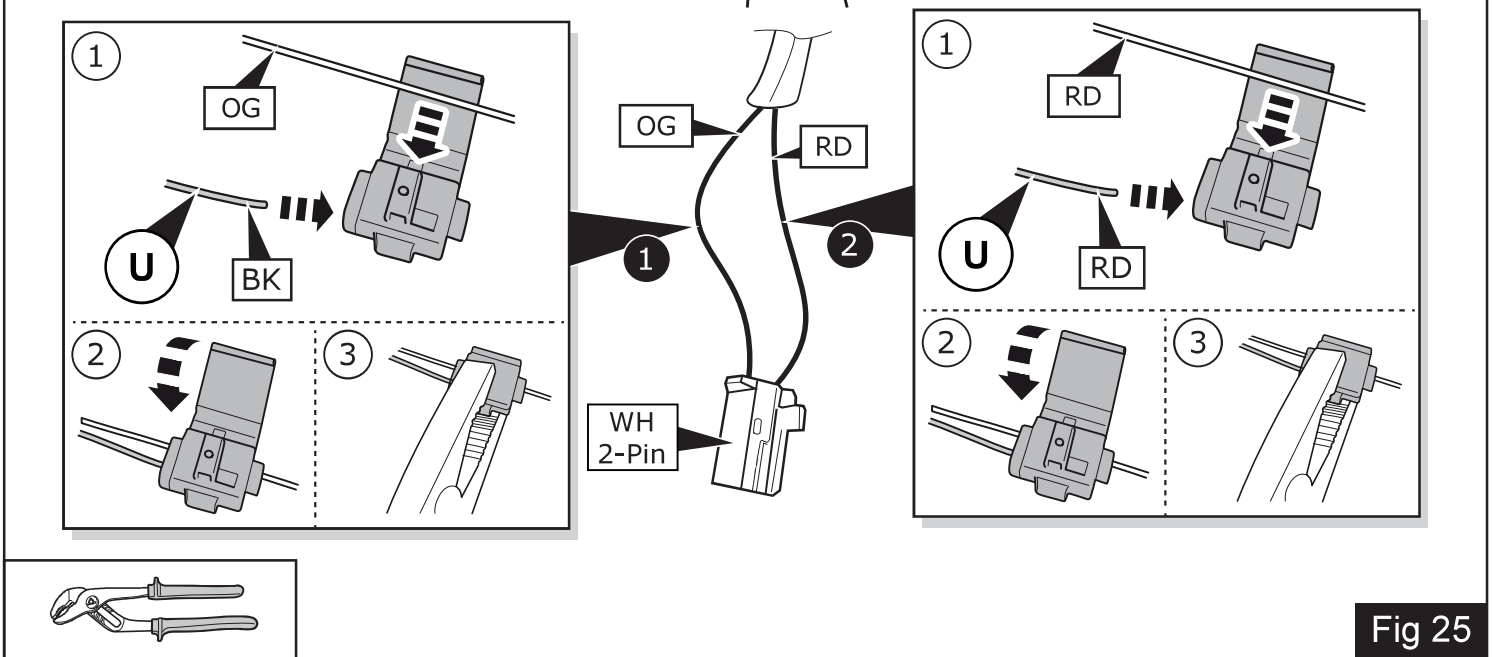
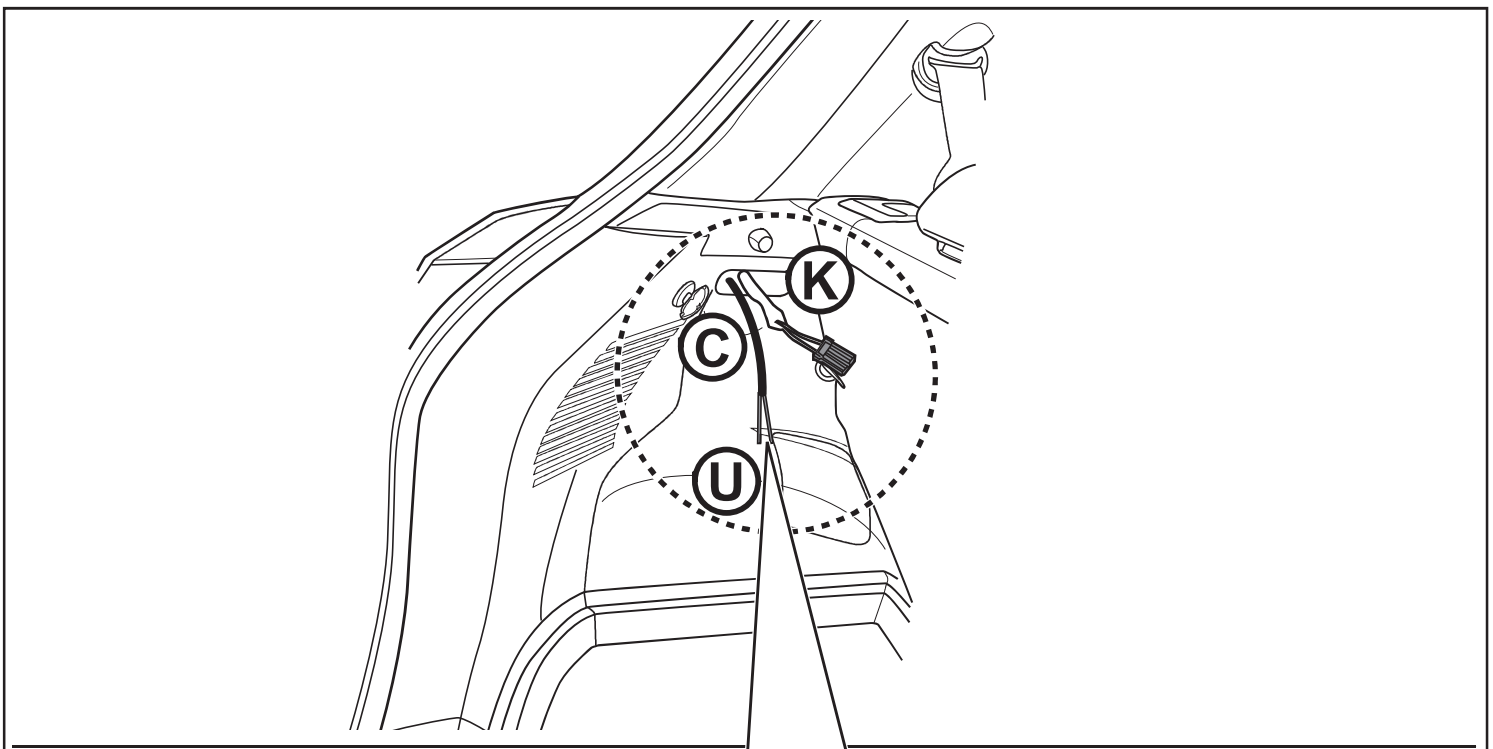
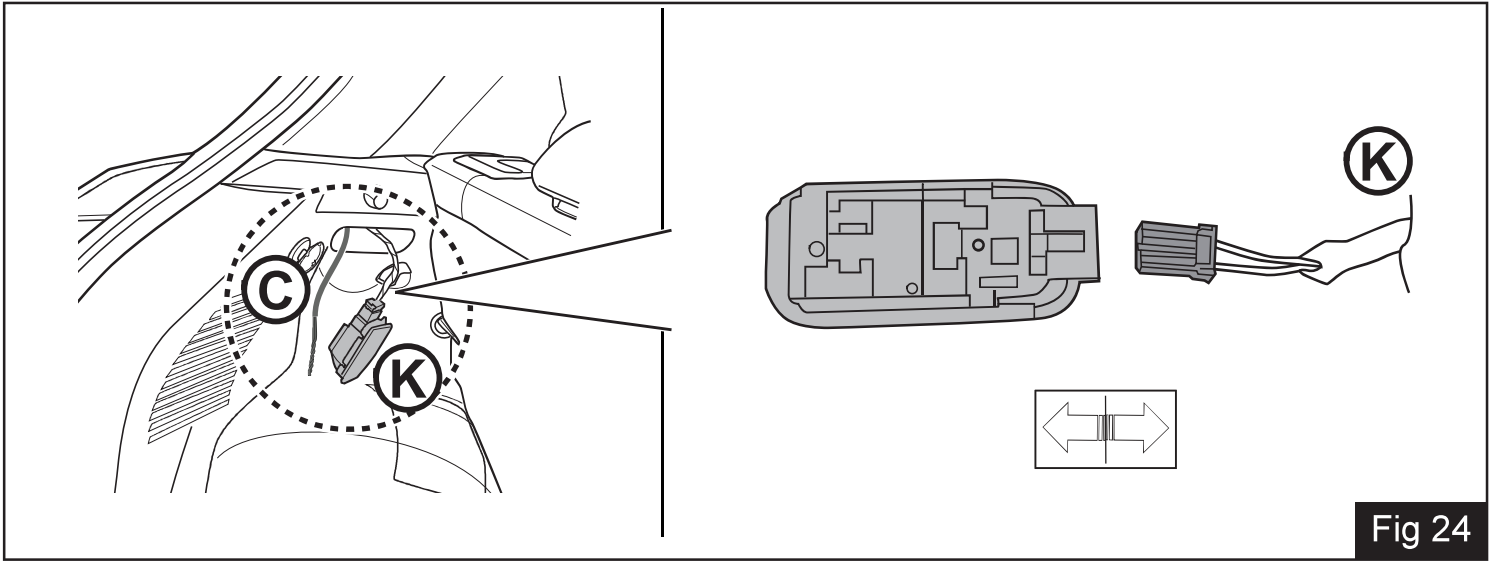

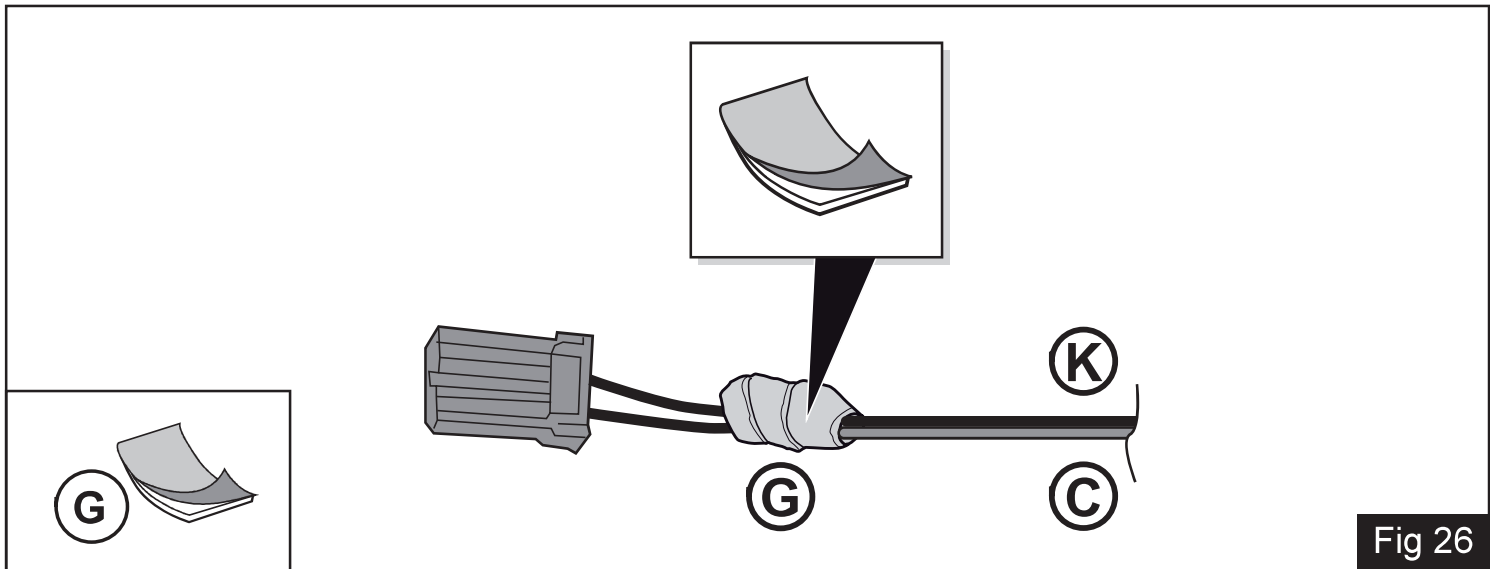

Fig 26

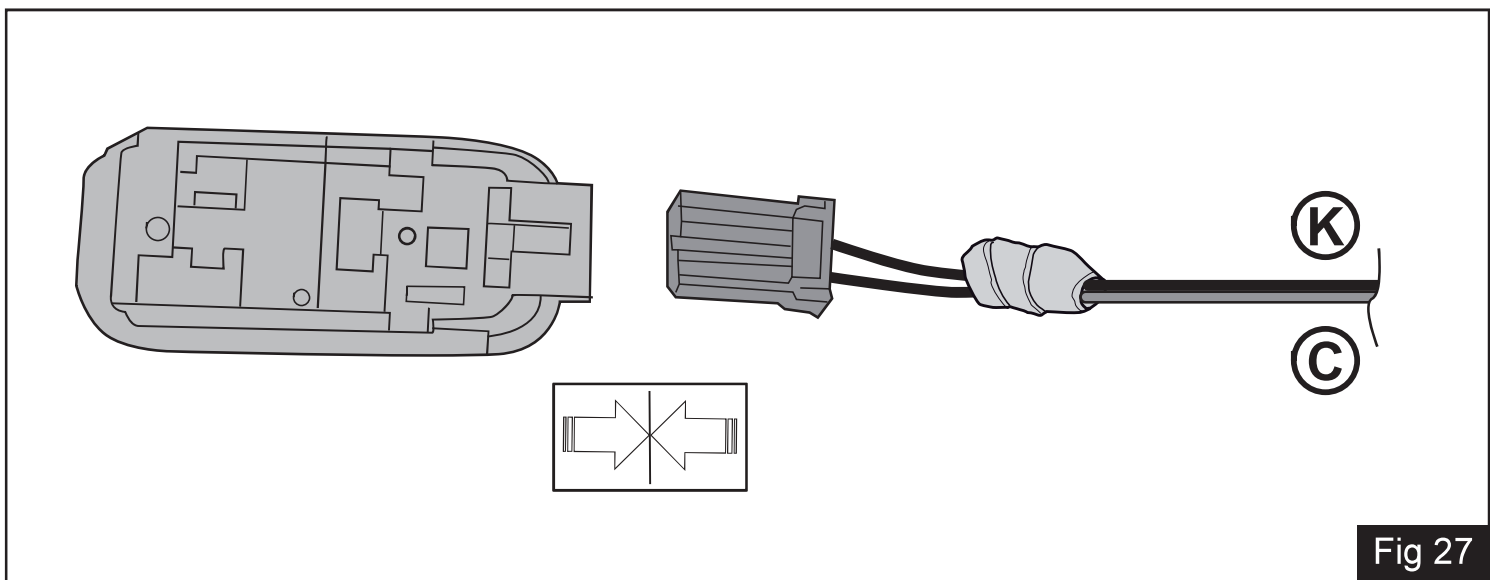

Fig 27

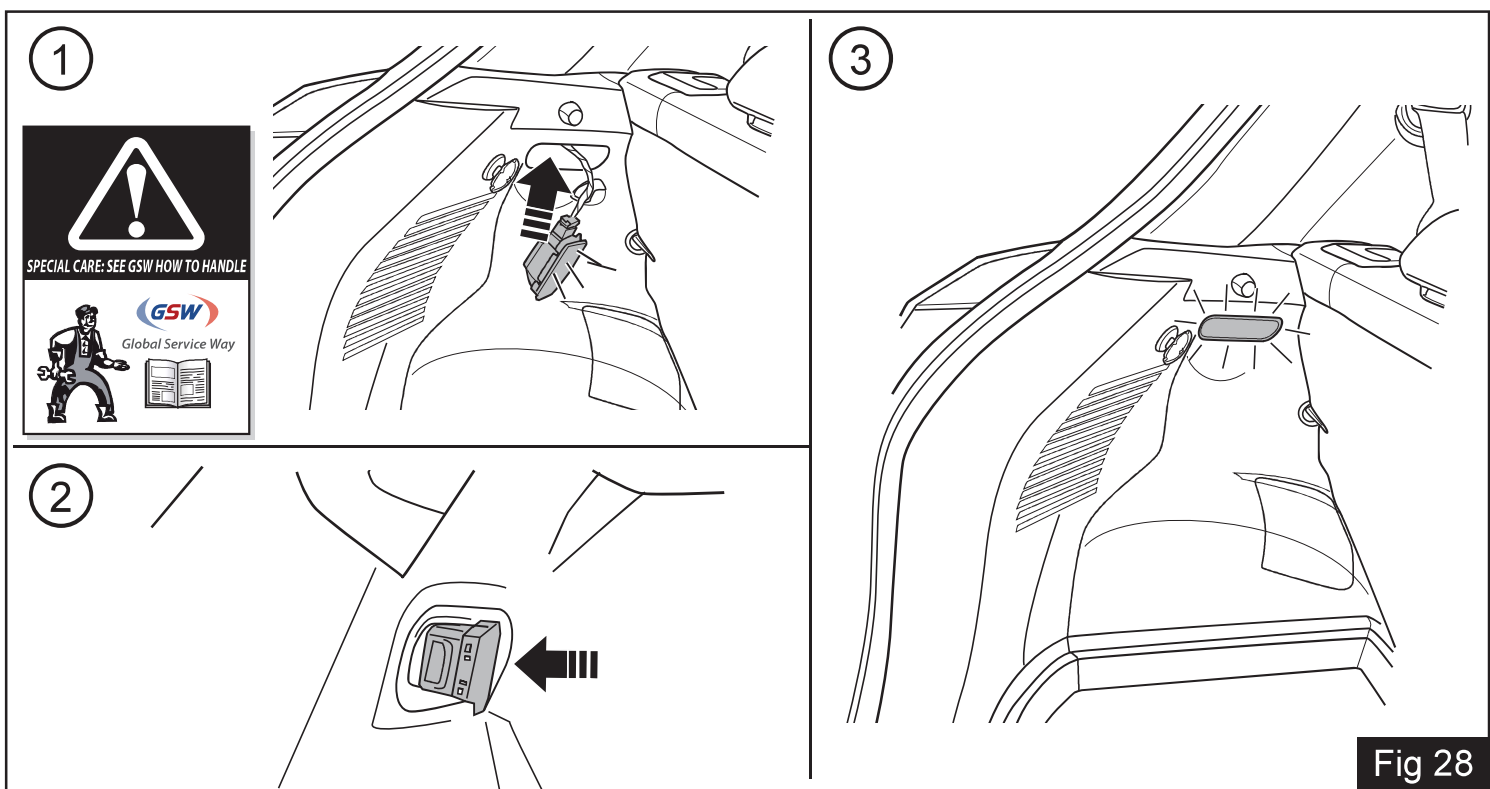

Fig 28

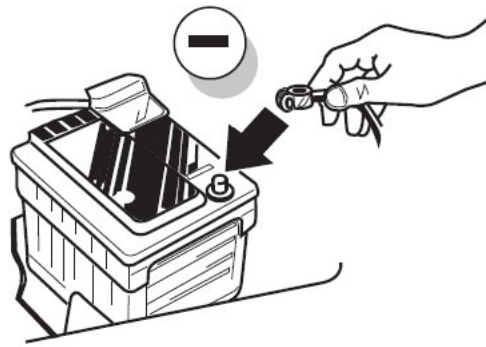
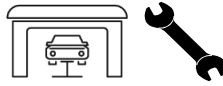

Fig 29



Reference picture

Fig 30